

SERVICE & OPERATING MANUAL



Model S05 Metallic Design Level 1

Table of Contents

Engineering Data and Temperature Limitations.....	1	Solenoid Shifted Air Distribution Valve Option.....	21
Explanation of Pump Nomenclature.....	2	Diaphragm Service Drawing, Non-Overlay.....	22
Performance Curve.....	3	Diaphragm Service Drawing, with Overlay.....	22
Dimensions (Aluminum Model).....	4	Diaphragm Service Drawing.....	22
Metric Dimensions (Aluminum Model).....	5	Diaphragm Servicing.....	23
Dimensions (Stainless Steel and Alloy C Models).....	6	Overlay Diaphragm Servicing.....	23
Metric Dimensions (Stainless Steel and Alloy C Models).....	7	Pilot Valve Servicing, Assembly Drawing & Parts List.....	24
Principle of Pump Operation.....	8	Intermediate Assembly Drawing and Parts List.....	25
Installation and Start-up.....	8	Intermediate Assembly and Actuator Plunger Servicing.....	25
Air Supply.....	8	Check Valve Servicing.....	26
Air Valve Lubrication.....	8	Check Valve Drawing.....	26
Air Line Moisture.....	8	Optional Muffler Configuration Drawing.....	27
Air Inlet and Priming.....	8	Dual Port Option Drawing (Aluminum Model).....	28
Between Uses.....	8	Dual Porting Options (Aluminum Model).....	29
Installation Guide.....	9	Dual Porting Suction and Discharge (Aluminum Model).....	29
Troubleshooting.....	10	Single Porting Suction and Dual Porting Discharge (Aluminum Model).....	30
Warranty.....	10	Dual Porting Suction and Single Porting Discharge (Aluminum Model).....	30
Recycling.....	11	Single Port Suction and Discharge Repair Parts List (Aluminum Model).....	30
Important Safety Information.....	11	Dual Port Suction and Discharge Repair Parts List (Aluminum Model).....	30
Material Codes.....	12	Pumping Hazardous Liquids.....	31
Composite Repair Parts Drawing.....	14	Converting the Pump For Piping the Exhaust Air.....	31
Available Service and Conversion Kits.....	14	Exhaust Conversion Drawing.....	31
Composite Repair Parts List.....	15	Converted Exhaust Illustration.....	31
Air Distribution Valve Assembly Drawing and Parts List.....	16	Pulse Output Kit Drawing.....	32
Air Distribution Valve Servicing.....	17	Pulse Output Kit Option.....	32
Air Valve with Stroke Indicator Assembly Drawing and Part List.....	18	Grounding the Pump.....	33
Air Distribution Valve with Stroke Indicator Option Servicing.....	19	CE Declaration of Conformity.....	34
Solenoid Shifted Air Valve Drawing and Parts List.....	20		



See page 2
for ATEX ratings.



U.S. Patent #
5,996,627 & 6,241,487
Other U.S. Patents
Applied for



**WARREN
RUPP®**

Quality System
ISO9001 Certified

Environmental
Management System
ISO14001 Certified

IDEX
FLUID & METERING

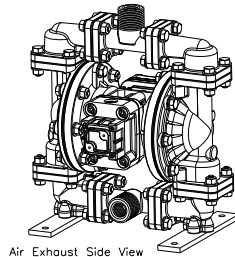

ALUMINUM
MODEL

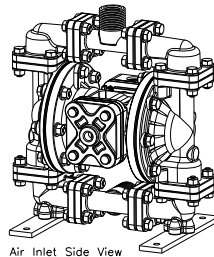

Air Inlet Side View

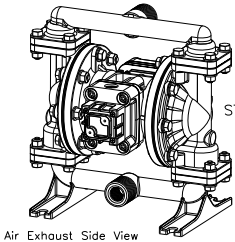

STAINLESS STEEL
AND ALLOY C
MODELS

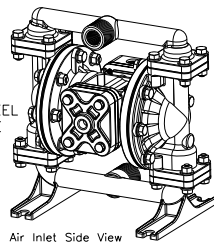

Air Inlet Side View



See page 2
for ATEX ratings.



U.S. Patent #
5,996,627; 6,241,487
Other U.S. Patents
Applied for

SANDPIPER®

A WARREN RUPP PUMP BRAND

**S05 Metallic
Design Level 1
Ball Valve**

**Air-Operated
Double Diaphragm Pump**

ENGINEERING, PERFORMANCE
& CONSTRUCTION DATA

INTAKE/DISCHARGE PIPE SIZE ½" NPT or ½" BSP (Tapered) 1" NPT or 1" BSP (Tapered)	CAPACITY 0 to 15 gallons per minute (0 to 56 liters per minute)	AIR VALVE No-lube, no-stall design	SOLIDS-HANDLING Up to .125 in. (3mm)	HEADS UP TO 125 psi or 289 ft. of water (8.6 Kg/cm ² or 86 meters)	DISPLACEMENT/STROKE .026 Gallon / .098 liter
---	--	---	--	--	--

CAUTION! Operating temperature limitations are as follows:

Materials

Operating Temperatures

Maximum

Minimum

Materials		Maximum	Minimum
Nitrile	General purpose, oil-resistant. Shows good solvent, oil, water and hydraulic fluid resistance. Should not be used with highly polar solvents like acetone and MEK, ozone, chlorinated hydrocarbons and nitro hydrocarbons.	190°F 88°C	-10°F -23°C
EPDM	Shows very good water and chemical resistance. Has poor resistance to oil and solvents, but is fair in ketones and alcohols.	280°F 138°C	-40°F -40°C
Neoprene	All Purpose. Resistant to vegetable oil. Generally not affected by moderate chemicals, fats, greases and many oils and solvents. Generally attacked by strong oxidizing acids, ketones, esters, nitro hydrocarbons and chlorinated aromatic hydrocarbons.	200°F 93°C	-10°F -23°C
Santoprene®	Injection molded thermoplastic elastomer with no fabric layer. Long mechanical flex life. Excellent abrasion resistance.	275°F 135°C	-40°F -40°C
Virgin PTFE	Chemically inert, virtually impervious. Very few chemicals are known to react chemically with PTFE: molten alkali metals, turbulent liquid or gases fluorine and a few fluoro-chemicals such as chlorine trifluoride or oxygen difluoride which readily liberate free fluorine at elevated temperatures.	220°F 104°C	-35°F -37°C
FKM (Fluorocarbon)	Shows good resistance to a wide range of oils and solvents; especially all aliphatic, aromatic and halogenated hydrocarbons, acids, animal and vegetable oils. Hot water or hot aqueous solutions (over 70°F) will attack FKM.	350°F 177°C	-40°F 40°C
Polyethylene		180°F 82°C	-40°F -40°C

SANDPIPER® pumps are designed to be powered only by compressed air.

For specific applications, always consult The Warren Rupp Chemical Resistance Chart

Explanation of Pump Nomenclature

S05 Metallic · Design Level 1 · Ball Valve

MODEL	Pump Brand	Pump Size	Check Valve Type	Design Level	Wetted Material	Diaphragm/Check Valve Materials	Check Valve Seat	Non-Wetted Material Options	Porting Options	Pump Style	Pump Options	Kit Options	Shipping Weight lbs. (kg)
S05B1ABWANS000.	S	05	B	1	A	B	W	A	N	S	0	00.	15 (7)
S05B1ACTANS000.	S	05	B	1	A	C	T	A	N	S	0	00.	15 (7)
S05B1ANWANS000.	S	05	B	1	A	N	W	A	N	S	0	00.	15 (7)
S05B1AXTANS000.	S	05	B	1	A	X	T	A	N	S	0	00.	15 (7)
S05B1A1WANS000.	S	05	B	1	A	1	W	A	N	S	0	00.	15 (7)
S05B1A2TANS000.	S	05	B	1	A	2	T	A	N	S	0	00.	15 (7)
S05B1SCTANS000.	S	05	B	1	S	C	T	A	N	S	0	00.	21 (10)
S05B1SEWANS000.	S	05	B	1	S	E	W	A	N	S	0	00.	21 (10)
S05B1SNWANS000.	S	05	B	1	S	N	W	A	N	S	0	00.	21 (10)
S05B1SXTANS000.	S	05	B	1	S	X	T	A	N	S	0	00.	21 (10)
S05B1S1WANS000.	S	05	B	1	S	1	W	A	N	S	0	00.	21 (10)

Note: Models listed in the table are for reference only. See nomenclature below for other models.

Pump Brand
S= SANDPIPER®

Pump Size
05= ½"

Check Valve Type
B= Ball

Design Level
1= Design Level

Wetted Material
A= Aluminum
S= Stainless Steel
H= Alloy C

Diaphragm/Check Ball Material
B= Nitrile/Nitrile
C= FKM/PTFE
N= Neoprene/Neoprene
E= EPDM/EPDM

Diaphragm/Check Ball Material Cont.

1= Santoprene/Santoprene
2= PTFE-Santoprene/PTFE
Z= One Piece PTFE-Nitrile/PTFE

Valve Seat

A= Aluminum
C= Cast Iron
H= Alloy C
S= Stainless Steel
T= PTFE
W= UHMW Polyethylene

Non-Wetted Material

A= Aluminum
Y= Aluminum With Stainless Steel hardware

Porting Options

N= NPT Threads
B= BSP (Tapered) Threads
1= Dual Porting (NPT)
2= Top Dual Porting (NPT)
Porting Options Cont.
3= Bottom Dual Porting NPT
4= Dual Porting BSP (Tapered)
5= Top Dual Porting BSP (Tapered)
6= Bottom Dual Porting BSP (Tapered)

Pump Style

S= Standard

Pump Options

0= Integral Muffler
1= Sound Dampening Muffler
2= Mesh Muffler
6= Metal Muffler
7= Metal Muffler with grounding cable

Kit Options



▲ 00.= None
P0.= 10-30VDC Pulse Output Kit
◇ P1.= Intrinsically-Safe 5-30VDC, 110/120VAC 220/240 VAC Pulse Output Kit
P2.= 110/120 or 220/240VAC Pulse Output Kit
▲ E0.= Solenoid Kit with 24VDC Coil
▲ E1.= Solenoid Kit with 24VDC Explosion-Proof Coil
▲ E2.= Solenoid Kit with 24VAC/12VDC Coil
▲ E3.= Solenoid Kit with 12VDC Explosion-Proof Coil
▲ E4.= Solenoid Kit with 110VAC Coil
▲ E5.= Solenoid Kit with 110VAC Explosion-Proof Coil
E6.= Solenoid Kit with 220VAC Coil

Kit Options continued

▲ E7.= Solenoid Kit with 220VAC Explosion-Proof Coil
▲ E8.= Solenoid Kit with 110VAC, 50 Hz Explosion-Proof Coil
▲ E9.= Solenoid Kit with 230VAC, 50 Hz Explosion-Proof Coil
SP.= Stroke Indicator Pins
◆ A1.= Solenoid Kit with 12 VDC Explosion-Proof Coil
◆ A2.= Solenoid Kit with 24 VDC Explosion-Proof Coil
◆ A3.= Solenoid Kit with 110/120 VAC 50/60 Hz Explosion-Proof Coil
◆ A4.= Solenoid Kit with 220/240 VAC 50/60 Hz Explosion-Proof Coil

(1)  II 2GD T5

▲ Note: Pumps are only ATEX compliant when ordered with pump option 6 or 7, and kit option 0.

(2)  II 2G Ex ia c IIC T5
 II 2D c iaD 20 IP67 T100°C

◇ Note: Pumps ordered with the options listed in (1) to the left are ATEX compliant when ordered with kit option P1.

(3*)  II 2G EEx m c T5
 II 2D c IP65 T100°C

◆ Note: Pumps ordered with the options listed in (1) to the left are ATEX compliant when ordered with kit option A1, A2, A3, or A4.

(4)  IEC EEx m T4

▲ Note: Pump models equipped with these explosion-proof solenoid kit options E1, E3, E5, E7, E8 or E9, are certified and approved by the above agencies. They are NOT ATEX compliant.

*Note: See page 20 for **Special Conditions For Safe Use.**

Performance Curve, S05 Metallic, Design Level 1

MODEL S05 Metallic Performance Curve

Performance based on the following: elastomer fitted pump, flooded suction, water at ambient conditions.
 The use of other materials and varying hydraulic conditions may result in deviations in excess of 5%.

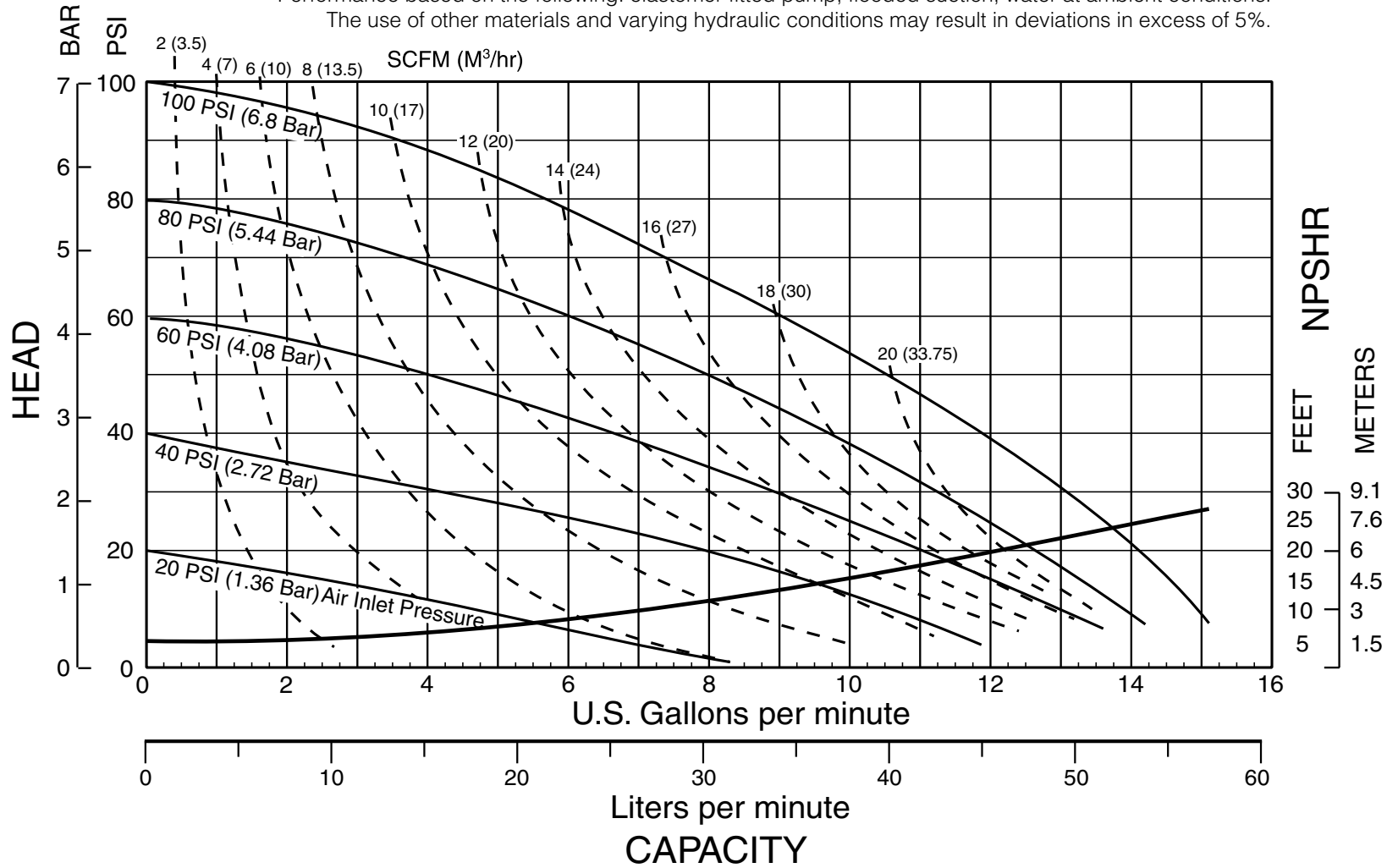

Dimensions: S05 Metallic (Aluminum Model)

Dimensions in Inches

Dimensional tolerance: $\pm 1/8$ "

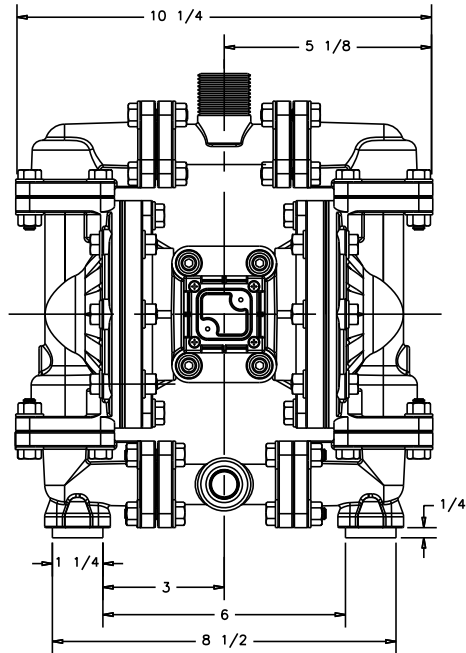

FRONT VIEW

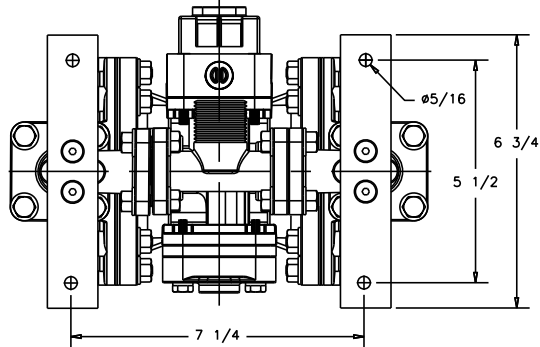

BOTTOM VIEW

ENCAPSULATED MUFFLER:
3/8" NPT EXHAUST PORT
FOR OPTIONAL PIPING MUFFLER
STYLES OR PIPING EXHAUST
AIR IN SUBMERGED
APPLICATIONS.

SUCTION PORT
1/2" NPT (INTERNAL)
1" NPT (EXTERNAL)

BOTH SUCTION AND DISCHARGE
PORTS ARE AVAILABLE IN
1/2" BSP TAPERED (INTERNAL)
1" BSP TAPERED (EXTERNAL)

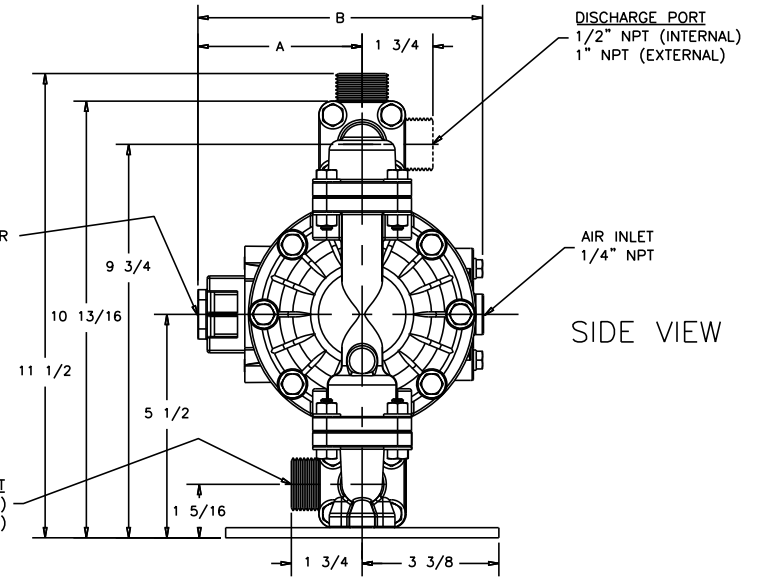

SIDE VIEW

DIMENSION	A	B
Integral Muffler	4 5/16"	7 5/16"
Pulse Output Kit	4 5/16"	7 5/16"
Mesh Muffler	6"	9"
Sound Dampening Muffler	6"	9"
Metal Muffler	5 5/8"	8 5/8"

Metric Dimensions: S05 Metallic (Aluminum Model)

Dimensions in millimeters
Dimensional tolerance: ±3mm

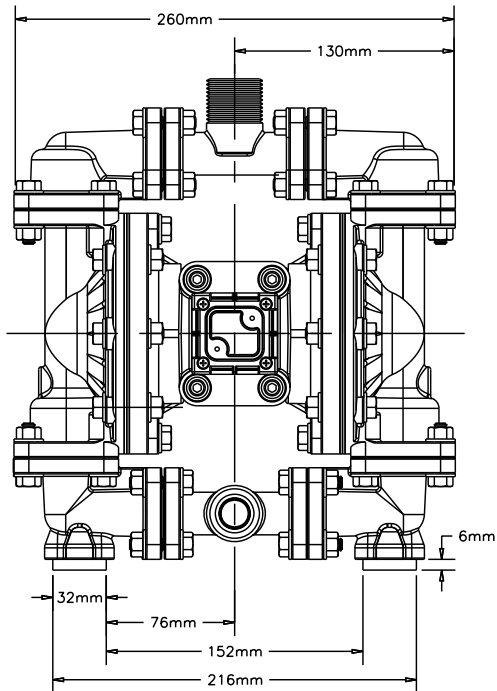

FRONT VIEW

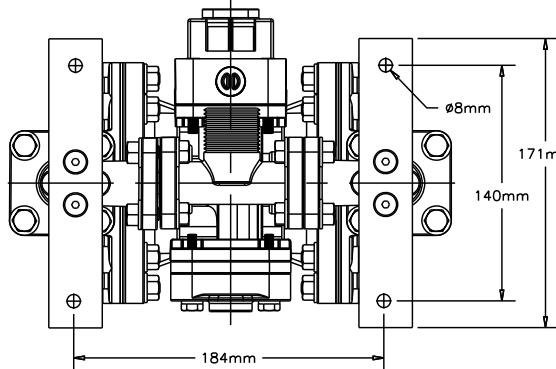

BOTTOM VIEW

ENCAPSULATED MUFFLER:
3/8" NPT EXHAUST PORT
FOR OPTIONAL PIPING MUFFLER
STYLES OR PIPING EXHAUST
AIR IN SUBMERGED
APPLICATIONS.

SUCTION PORT
1/2" NPT (INTERNAL)
1" NPT (EXTERNAL)

BOTH SUCTION AND DISCHARGE
PORTS ARE AVAILABLE IN
1/2" BSP TAPERED (INTERNAL)
1" BSP TAPERED (EXTERNAL)

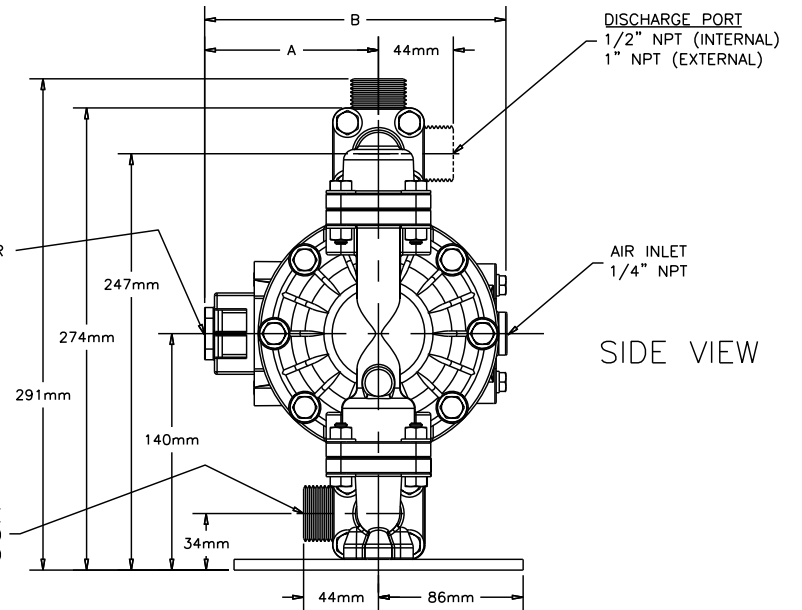

DISCHARGE PORT
1/2" NPT (INTERNAL)
1" NPT (EXTERNAL)

AIR INLET
1/4" NPT

SIDE VIEW

DIMENSION	A	B
Integral Muffler	109mm	186mm
Pulse Output Kit	109mm	186mm
Mesh Muffler	152mm	229mm
Sound Dampening Muffler	152mm	229mm
Metal Muffler	143 mm	219 mm

Dimensions: S05 Metallic (Stainless Steel & Alloy C Models)

Dimensions in Inches

Dimensional tolerance: $\pm 1/8$ "

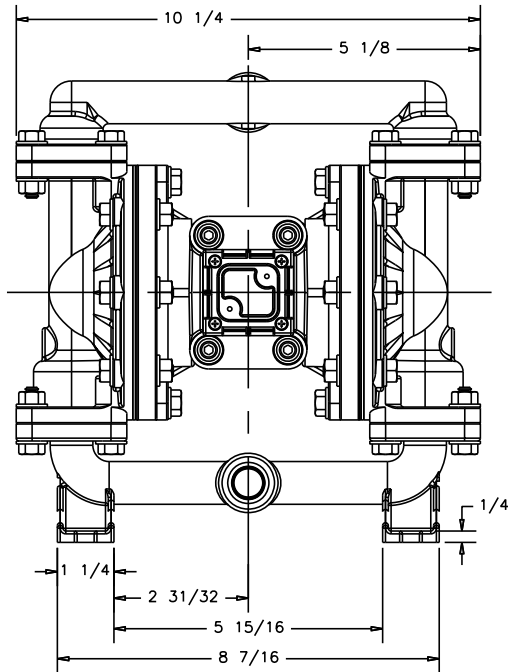

STANDARD ENCAPSULATED MUFFLER:
3/8" NPT EXHAUST PORT
FOR OPTIONAL PIPING MUFFLER
STYLES OR PIPING EXHAUST
AIR IN SUBMERGED
APPLICATIONS.

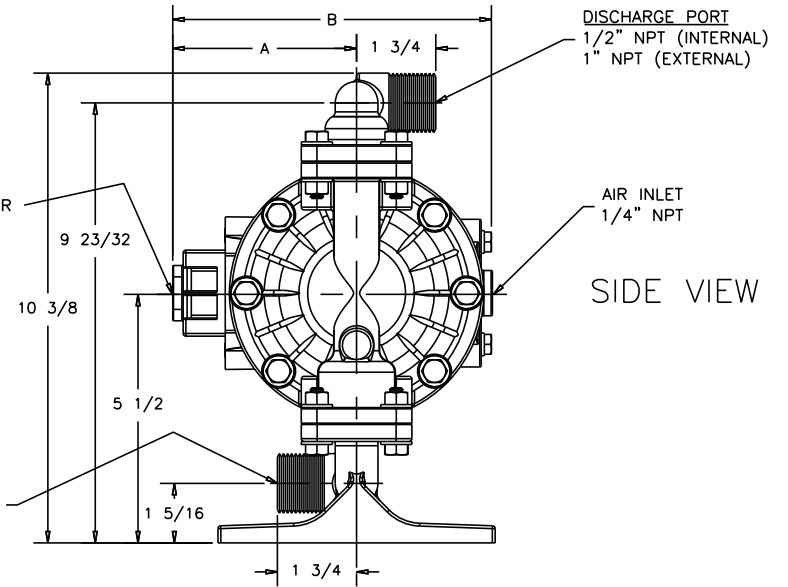

SUCTION PORT
1/2" NPT (INTERNAL)
1" NPT (EXTERNAL)

BOTH SUCTION AND DISCHARGE
PORTS ARE AVAILABLE IN
1/2" BSP TAPERED (INTERNAL)
1" BSP TAPERED (EXTERNAL)

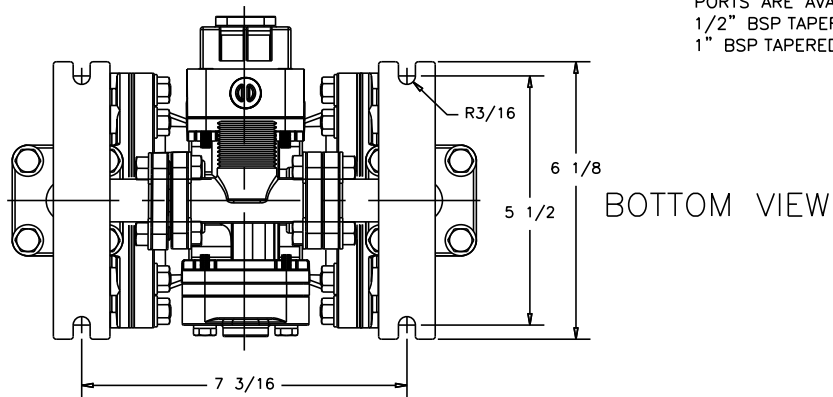

DIMENSION	A	B
Integral Muffler	4 5/16"	7 5/16"
Pulse Output Kit	4 5/16"	7 5/16"
Mesh Muffler	6"	9"
Sound Dampening Muffler	6"	9"
Metal Muffler	5 5/8"	8 5/8"

Metric Dimensions: S05 Metallic (Stainless Steel & Alloy C Models)

Dimensions in millimeters
Dimensional tolerance: $\pm 3\text{mm}$

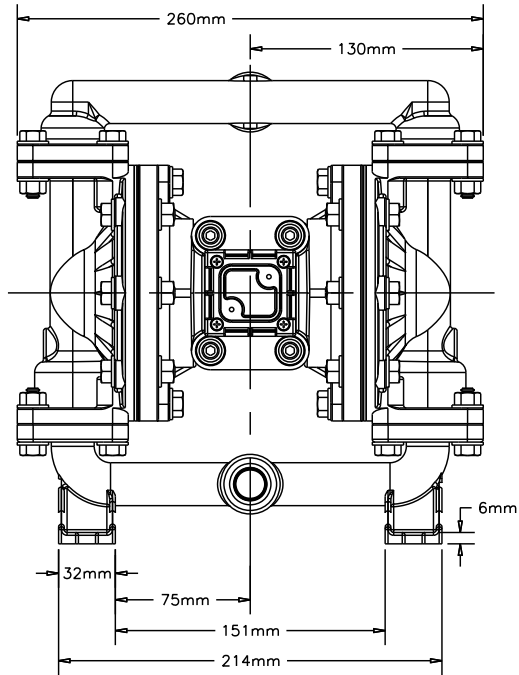

FRONT VIEW

STANDARD
ENCAPSULATED MUFFLER:
3/8" NPT EXHAUST PORT
FOR OPTIONAL PIPING MUFFLER
STYLES OR PIPING EXHAUST
AIR IN SUBMERGED
APPLICATIONS.

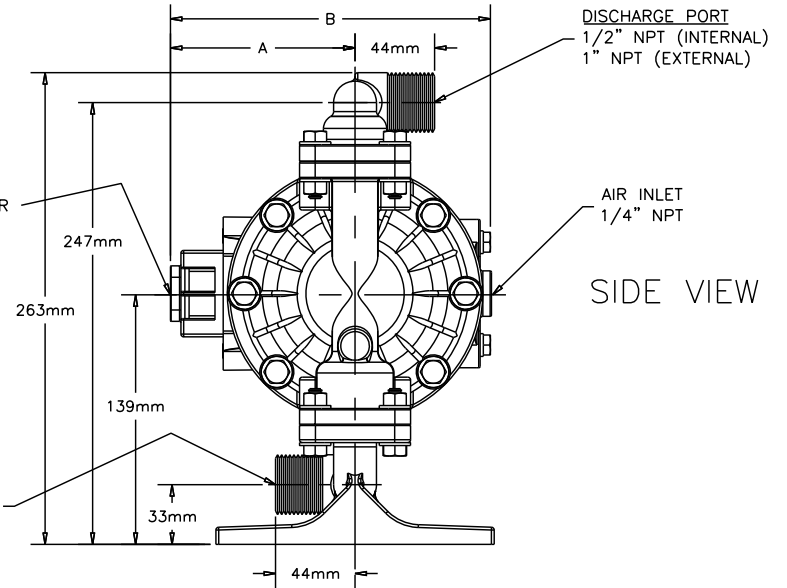

SIDE VIEW

SUCTION PORT
1/2" NPT (INTERNAL)
1" NPT (EXTERNAL)

BOTH SUCTION AND DISCHARGE
PORTS ARE AVAILABLE IN
1/2" BSP TAPERED (INTERNAL)
1" BSP TAPERED (EXTERNAL)

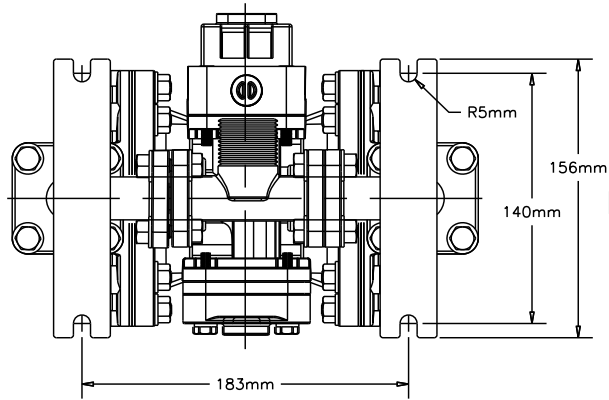

BOTTOM VIEW

DIMENSION	A	B
Integral Muffler	109mm	186mm
Pulse Output Kit	109mm	186mm
Mesh Muffler	152mm	229mm
Sound Dampening Muffler	152mm	229mm
Metal Muffler	143mm	219mm

PRINCIPLE OF PUMP OPERATION

This ball type check valve pump is powered by compressed air and is a 1:1 ratio design. The inner side of one diaphragm chamber is alternately pressurized while simultaneously exhausting the other inner chamber. This causes the diaphragms, which are connected by a common rod secured by plates to the centers of the diaphragms, to move in a reciprocating action. (As one diaphragm performs the discharge stroke the other diaphragm is pulled to perform the suction stroke in the opposite chamber.) Air pressure is applied over the entire inner surface of the diaphragm while liquid is discharged from the opposite side of the diaphragm. The diaphragm operates in a balanced condition during the discharge stroke which allows the pump to be operated at discharge heads over 200 feet (61 meters) of water.

For maximum diaphragm life, keep the pump as close to the liquid being pumped as possible. Positive suction head in excess of 10 feet of liquid (3.048 meters) may require a back pressure regulating device to maximize diaphragm life.

Alternate pressurizing and exhausting of the diaphragm chamber is performed by an externally mounted, pilot operated, four way spool type air distribution valve. When the spool shifts to one end of the valve body, inlet pressure is applied to one diaphragm chamber and the other diaphragm chamber exhausts. When the spool shifts to the opposite end of the valve body, the pressure to the chambers

is reversed. The air distribution valve spool is moved by a internal pilot valve which alternately pressurizes one end of the air distribution valve spool while exhausting the other end. The pilot valve is shifted at each end of the diaphragm stroke when a actuator plunger is contacted by the diaphragm plate. This actuator plunger then pushes the end of the pilot valve spool into position to activate the air distribution valve.

The chambers are connected with manifolds with a suction and discharge check valve for each chamber, maintaining flow in one direction through the pump.

INSTALLATION AND START-UP

Locate the pump as close to the product being pumped as possible. Keep the suction line length and number of fittings to a minimum. Do not reduce the suction line diameter.

For installations of rigid piping, short sections of flexible hose should be installed between the pump and the piping. The flexible hose reduces vibration and strain to the pumping system. A Warren Rupp DA05 Surge Dampener is recommended to further reduce pulsation in flow.

AIR SUPPLY

Air supply pressure cannot exceed 100 psi (7 bar). Connect the pump air inlet to an air supply of sufficient capacity and pressure required for desired performance. When the air supply line is solid piping, use a short length of flexible hose not less than 1/2" (13mm) in diameter between the pump and the piping to reduce strain

to the piping. The weight of the air supply line, regulators and filters must be supported by some means other than the air inlet cap. Failure to provide support for the piping may result in damage to the pump. A pressure regulating valve should be installed to insure air supply pressure does not exceed recommended limits.

AIR VALVE LUBRICATION

The air distribution valve and the pilot valve are designed to operate WITHOUT lubrication. This is the preferred mode of operation. There may be instances of personal preference or poor quality air supplies when lubrication of the compressed air supply is required. The pump air system will operate with properly lubricated compressed air supply. Proper lubrication requires the use of an air line lubricator (available from Warren Rupp) set to deliver one drop of SAE 10 non-detergent oil for every 20 SCFM (9.4 liters/sec.) of air the pump consumes at the point of operation. Consult the pump's published Performance Curve to determine this.

AIR LINE MOISTURE

Water in the compressed air supply can create problems such as icing or freezing of the exhaust air, causing the pump to cycle erratically or stop operating. Water in the air supply can be reduced by using a point-of-use air dryer to supplement the user's air drying equipment. This device removes water from the compressed air supply and alleviates the icing or freezing problems.

AIR INLET AND PRIMING

To start the pump, open the air valve approximately 1/2" to 3/4" turn. After the pump primes, the air valve can be opened to increase air flow as desired. If opening the valve increases cycling rate, but does not increase the rate of flow, cavitation has occurred. The valve should be closed slightly to obtain the most efficient air flow to pump flow ratio.

BETWEEN USES

When the pump is used for materials that tend to settle out or solidify when not in motion, the pump should be flushed after each use to prevent damage. (Product remaining in the pump between uses could dry out or settle out. This could cause problems with the diaphragms and check valves at restart.) In freezing temperatures the pump must be completely drained between uses in all cases.

TYPICAL INSTALLATION GUIDE For Metallic Pumps

Available from
Warren Rupp

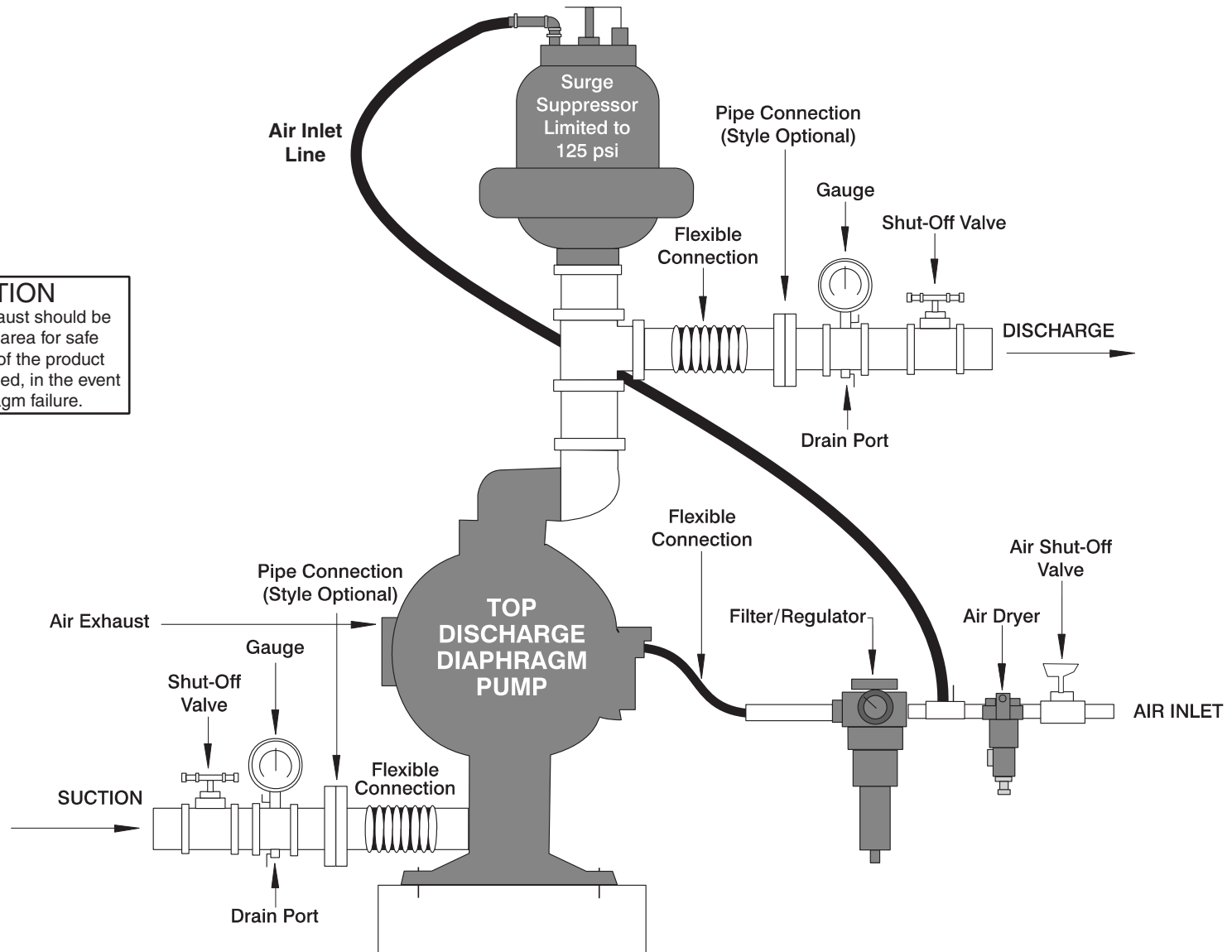
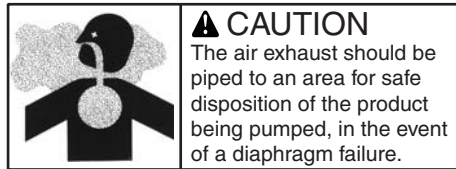

TROUBLESHOOTING

Possible Symptoms:

- Pump will not cycle.
- Pump cycles, but produces no flow.
- Pump cycles, but flow rate is unsatisfactory.
- Pump cycle seems unbalanced.
- Pump cycle seems to produce excessive vibration.

What to Check: Excessive suction lift in system.

Corrective Action: For lifts exceeding 20 feet (6 meters), filling the pumping chambers with liquid will prime the pump in most cases.

What to Check: Excessive flooded suction in system.

Corrective Action: For flooded conditions exceeding 10 feet (3 meters) of liquid, install a back pressure device.

What to Check: System head exceeds air supply pressure.

Corrective Action: Increase the inlet air pressure to the pump. Most diaphragm pumps are designed for 1:1 pressure ratio at zero flow.

What to Check: Air supply pressure or volume exceeds system head.

Corrective Action: Decrease inlet air pressure and volume to the pump as calculated on the published PERFORMANCE CURVE. Pump is cavitating the fluid by fast cycling.

What to Check: Undersized suction line.

Corrective Action: Meet or exceed pump connection recommendations shown on the DIMENSIONAL DRAWING.

What to Check: Restricted or undersized air line.

Corrective Action: Install a larger air line and connection. Refer to air inlet recommendations shown in your pump's SERVICE MANUAL.

What to Check: Check ESADS+Plus, the Externally Serviceable Air Distribution System of the pump.

Corrective Action: Disassemble and inspect the main air distribution valve, pilot valve and pilot valve actuators. Refer to the parts drawing and air valve section of the SERVICE MANUAL. Check for clogged discharge or closed valve before reassembly.

What to Check: Rigid pipe connections to pump.

Corrective Action: Install flexible connectors and a Warren Rupp surge dampener.

What to Check: Blocked air exhaust muffler.

Corrective Action: Remove muffler screen, clean or de-ice and reinstall. Refer to the Air Exhaust section of your pump SERVICE MANUAL.

What to Check: Pumped fluid in air exhaust muffler.

Corrective Action: Disassemble pump chambers. Inspect for diaphragm rupture or loose diaphragm plate assembly. Refer to the Diaphragm Replacement section of your pump SERVICE MANUAL.

What to Check: Suction side air leakage or air in product.

Corrective Action: Visually inspect all suction side gaskets and pipe connections.

What to Check: Obstructed check valve.

Corrective Action: Disassemble the wet end of the pump and manually dislodge obstruction in the check valve pocket. Refer to the Check Valve section of the pump SERVICE MANUAL for disassembly instructions.

What to Check: Worn or misaligned check valve or check valve seat.

Corrective Action: Inspect check valves and seats for wear and proper seating. Replace if necessary. Refer to Check Valve section of the pump SERVICE MANUAL for disassembly instructions.

What to Check: Blocked suction line.

Corrective Action: Remove or flush obstruction. Check and clear all suction screens and strainers.

What to Check: Blocked discharge line.

Corrective Action: Check for obstruction or closed discharge line valves.

What to Check: Blocked pumping chamber.

Corrective Action: Disassemble and inspect the wetted chambers of the pump. Remove or flush any obstructions. Refer to the pump SERVICE MANUAL for disassembly instructions.

What to Check: Entrained air or vapor lock in one or both pumping chambers.

Corrective Action: Purge chambers through tapped chamber vent plugs. PURGING THE CHAMBERS OF AIR CAN BE DANGEROUS! Contact the Warren Rupp Technical Services Group before performing this procedure. A model with top-ported discharge will reduce or eliminate problems with entrained air.

If your pump continues to perform below your expectations, contact your local Warren Rupp Distributor or factory Technical Services Group for a service evaluation.

WARRANTY

Refer to the enclosed Warren Rupp Warranty Card.

RECYCLING

Many components of SANDPIPER® AODD pumps are made of recyclable materials (see chart on page 12 for material specifications). We encourage pump users to recycle worn out parts and pumps whenever possible, after any hazardous pumped fluids are thoroughly flushed.



II 2GD T5

Pump complies with EN809 Pumping Directive, Directive 98/37/EC Safety of Machinery, and Directive 94/9/EC, EN13463-1 Equipment for use in Potentially Explosive Environments. For reference to the directive certificates visit: www.warrenrupp.com. The Technical File No. AX1 is stored at KEMA, Notified Body 0344, under Document #203040000.

IMPORTANT SAFETY INFORMATION



IMPORTANT

Read these safety warnings and instructions in this manual completely, before installation and start-up of the pump. It is the responsibility of the purchaser to retain this manual for reference. Failure to comply with the recommendations stated in this manual will damage the pump, and void factory warranty.



CAUTION

Before pump operation, inspect all gasketed fasteners for looseness caused by gasket creep. Retorque loose fasteners to prevent leakage. Follow recommended torques stated in this manual.



WARNING

Before maintenance or repair, shut off the compressed air line, bleed the pressure, and disconnect the air line from the pump. The discharge line may be pressurized and must be bled of its pressure.



WARNING

In the event of diaphragm rupture, pumped material may enter the air end of the pump, and be discharged into the atmosphere. If pumping a product which is hazardous or toxic, the air exhaust must be piped to an appropriate area for safe disposition.



WARNING

Take action to prevent static sparking. Fire or explosion can result, especially when handling flammable liquids. The pump, piping, valves, containers or other miscellaneous equipment must be grounded. (See page 33)



WARNING

This pump is pressurized internally with air pressure during operation. Always make certain that all bolting is in good condition and that all of the correct bolting is reinstalled during assembly.



WARNING

When used for toxic or aggressive fluids, the pump should always be flushed clean prior to disassembly.



WARNING

Before doing any maintenance on the pump, be certain all pressure is completely vented from the pump, suction, discharge, piping, and all other openings and connections. Be certain the air supply is locked out or made non-operational, so that it cannot be started while work is being done on the pump. Be certain that approved eye protection and protective clothing are worn all times in the vicinity of the pump. Failure to follow these recommendations may result in serious injury or death.



WARNING

Airborne particles and loud noise hazards. Wear ear and eye protection.

Material Codes

The Last 3 Digits of Part Number

000	Assembly, sub-assembly; and some purchased items	180	Copper Alloy	378	High Density Polypropylene	604	PTFE
010	Cast Iron	305	Carbon Steel, Black Epoxy Coated	379	Conductive Nitrile	606	PTFE
012	Powered Metal	306	Carbon Steel, Black PTFE Coated	405	Cellulose Fibre	607	Envelon
015	Ductile Iron	307	Aluminum, Black Epoxy Coated	408	Cork and Neoprene	608	Conductive PTFE
020	Ferritic Malleable Iron	308	Stainless Steel, Black PTFE Coated	425	Compressed Fibre	610	PTFE Integral Silicon
025	Music Wire	309	Aluminum, Black PTFE Coated	426	Blue Gard	611	PTFE Integral FKM
080	Carbon Steel, AISI B-1112	310	PVDF Coated	440	Vegetable Fibre	632	Neoprene/Hytrel
100	Alloy 20	330	Zinc Plated Steel	465	Fibre	633	FKM (Fluorocarbon)/PTFE
110	Alloy Type 316 Stainless Steel	331	Chrome Plated Steel	500	Delrin 500	634	EPDM/PTFE
111	Alloy Type 316 Stainless Steel (Electro Polished)	332	Aluminum, Electroless Nickel Plated	501	Delrin 570	635	Neoprene/PTFE
112	Alloy C	333	Carbon Steel, Electroless Nickel Plated	502	Conductive Acetal, ESD-800	637	PTFE, FKM (Fluorocarbon)/PTFE
113	Alloy Type 316 Stainless Steel (Hand Polished)	335	Galvanized Steel	503	Conductive Acetal, Glass-Filled	638	PTFE, Hytrel/PTFE
114	303 Stainless Steel	336	Zinc Plated Yellow Brass	505	Acrylic Resin Plastic	639	Nitrile/TFE
115	302/304 Stainless Steel	337	Silver Plated Steel	506	Delrin 150	643	Santoprene/EPDM
117	440-C Stainless Steel (Martensitic)	340	Nickel Plated	520	Injection Molded PVDF Natural color	644	Santoprene/PTFE
120	416 Stainless Steel (Wrought Martensitic)	342	Filled Nylon	521	Conductive PVDF	650	Bonded Santoprene and PTFE
123	410 Stainless Steel (Wrought Martensitic)	353	Geolast; Color: Black	540	Nylon	654	Santoprene Diaphragm, PTFE Overlay Balls and seals
148	Hardcoat Anodized Aluminum	354	Injection Molded #203-40 Santoprene- Duro 40D +/-5; Color: RED	541	Nylon	656	Santoprene Diaphragm and Check Balls/EPDM Seats
149	2024-T4 Aluminum	355	Thermal Plastic	542	Nylon	661	EPDM/Santoprene
150	6061-T6 Aluminum	356	Hytrel	544	Nylon Injection Molded		
151	6063-T6 Aluminum	357	Injection Molded Polyurethane	550	Polyethylene		Delrin and Hytrel are registered tradenames of E.I. DuPont.
152	2024-T4 Aluminum (2023-T351)	358	Urethane Rubber (Some Applications) (Compression Mold)	551	Glass Filled Polypropylene		Gylon is a registered tradename of Garlock, Inc.
154	Almag 35 Aluminum	359	Urethane Rubber	552	Unfilled Polypropylene		Nylatron is a registered tradename of Polymer Corp.
155	356-T6 Aluminum	360	Nitrile Rubber. Color coded: RED	553	Unfilled Polypropylene		Santoprene is a registered tradename of Monsanto Corp.
156	356-T6 Aluminum	361	FDA Accepted Nitrile	555	Polyvinyl Chloride		Rulon II is a registered tradename of Dixion Industries Corp.
157	Die Cast Aluminum Alloy #380	363	FKM (Fluorocarbon). Color coded: YELLOW	556	Black Vinyl		Ryton is a registered tradename of Phillips Chemical Co.
158	Aluminum Alloy SR-319	364	E.P.D.M. Rubber. Color coded: BLUE	557	Conductive Polypropylene		Valox is a registered tradename of General Electric Co.
159	Anodized Aluminum	365	Neoprene Rubber. Color coded: GREEN	558	Conductive HDPE		Warren Rupp, SANDPIPER, Portapump, Tranquilizers and SludgeMaser are registered tradenames of Warren Rupp, Inc.
162	Brass, Yellow, Screw Machine Stock	366	Food Grade Nitrile	559	Glass-Filled Conductive Polypropylene		
165	Cast Bronze, 85-5-5-5	368	Food Grade EPDM	570	Rulon II		
166	Bronze, SAE 660	370	Butyl Rubber. Color coded: BROWN	580	Ryton		
170	Bronze, Bearing Type, Oil Impregnated	371	Philthane (Tuftane)	590	Valox		
175	Die Cast Zinc	374	Carboxylated Nitrile	591	Nylatron G-S		
		375	Fluorinated Nitrile	592	Nylatron NSB		
				600	PTFE (virgin material)		
				601	Tetrafluorocarbon (TFE)		
				602	PTFE (Bronze and moly filled)		
				603	Filled PTFE		
					Blue Gylon		

Composite Repair Parts Drawing

Available Service and Conversion Kits

PART NO.	DESCRIPTION
476-239-000	AIR END KIT Seals, O-rings, Gaskets, Bumpers, Retainers, Air Valve Assembly and Pilot Valve Assembly.
476-240-000	AIR END KIT for pumps equipped with Stroke Indicator (same components as above, except Air Valve Assembly with pins replaces Air Valve Standard).
476-199-354	WETTED END KIT Santoprene Diaphragm, Santoprene Check Balls, UHMW Seats, Nitrile Spacer Gasket.
476-199-356	WETTED END KIT Hytrek Diaphragm, Hytrek Check Balls, UHMW Seats.
476-199-360	WETTED END KIT Nitrile Diaphragm, Nitrile Check Balls, UHMW Seats.
476-199-661	WETTED END KIT EPDM Diaphragm, Santoprene Check Balls, UHMW Seats.
476-199-365	WETTED END KIT Neoprene Diaphragm, Neoprene Check Balls, UHMW Seats.
476-199-633	WETTED END KIT FKM Diaphragm, PTFE Check Balls, PTFE Seats.
476-199-650	WETTED END KIT PTFE and Santoprene Diaphragm, PTFE Check Balls, PTFE Seats.
476-199-654	WETTED END KIT Santoprene Diaphragm, PTFE Overlay Diaphragm, PTFE Check Balls, PTFE Seats.
476-199-659	WETTED END KIT One-Piece Bonded PTFE/Nitrile Diaphragm, PTFE Balls, PTFE Seats.

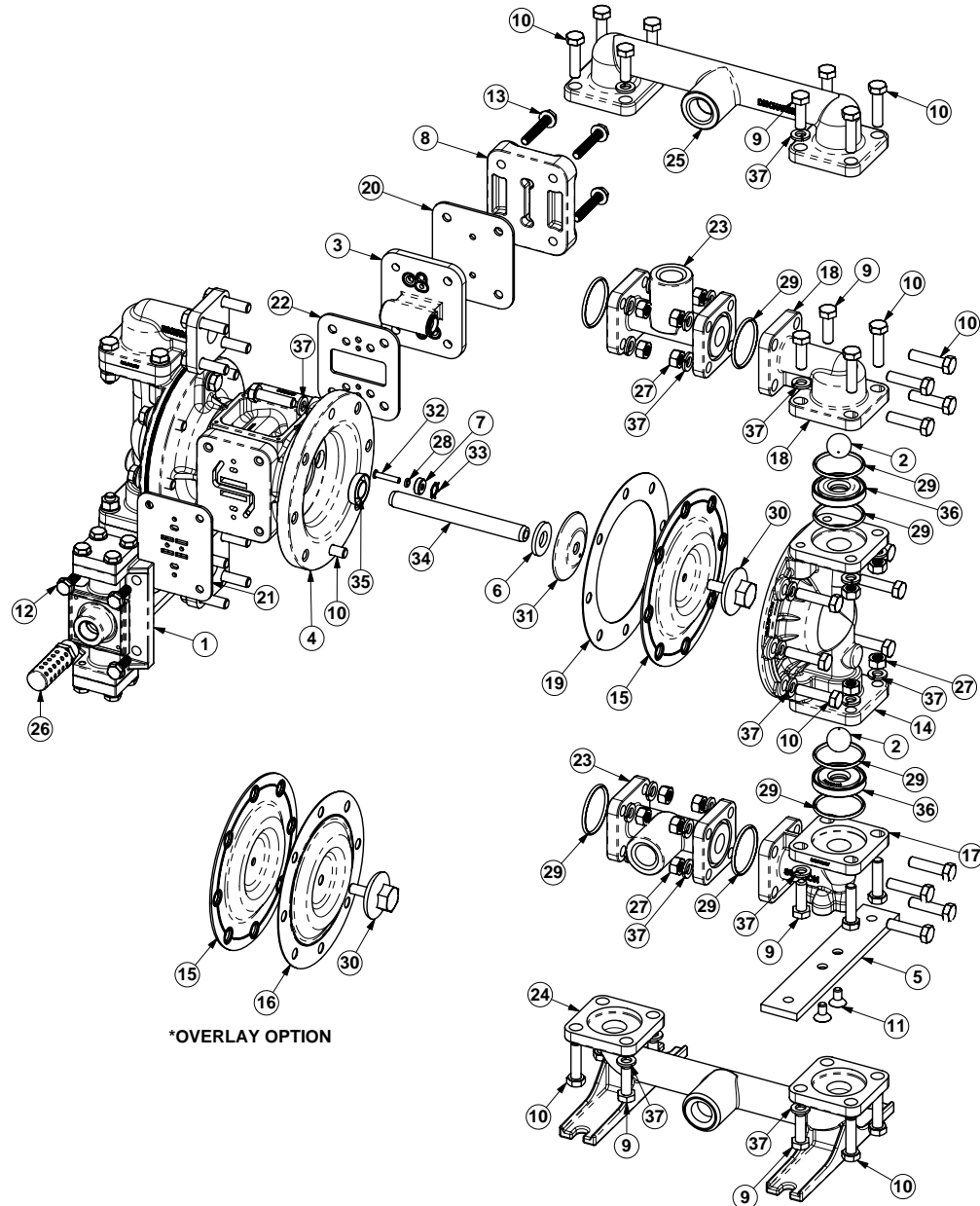

Composite Repair Parts List

ITEM	PART NUMBER	DESCRIPTION	QTY
1	031-191-000	Air Valve Assembly (Integral Muffler)	1
	▲ 031-167-000	Air Valve Assembly (w/ stroke Indicator Pins)	1
	▲ 031-186-000	Air Valve Assembly	1
	▲ 031-169-000	Air Valve Assembly (Stroke Indicator & Optional Mufflers)	1
	▲ 031-186-003	Air Valve Assembly w/ Stainless Steel hardware	1
	▲ 031-186-002	Air Valve (High Temperature)	1
	031-191-002	Air Valve (High Temperature With Integral Mufflers)	1
	031-191-003	Air Valve Assembly (Stainless Steel Hardware)	1
2	050-022-600	Ball, Check	4
	050-027-354	Ball, Check	4
	050-027-356	Ball, Check	4
	050-027-360	Ball, Check	4
	050-027-364	Ball, Check	4
	050-027-365	Ball, Check	4
3	095-116-000	Pilot Valve Assembly	1
4	114-023-157	Bracket, Intermediate	1
5	115-152-151	Bracket, Mounting (Aluminum)	2
6	132-034-360	Bumper, Diaphragm	2
7	135-036-506	Bushing, Plunger	2
8	165-110-157	Cap, Air Inlet	1
9	170-044-115	Capscrew, Hex 5/16-18 X 1.00	8
	170-044-330	Capscrew, Hex 5/16-18 X 1.00	8
10	170-045-115	Capscrew, Hex 5/16-18 X 1.25 (alum)	40
	170-045-330	Capscrew, Hex 5/16-18 X 1.25 (alum)	40
	170-045-115	Capscrew, Hex 5/16-18 x 1.25 (ss)	24
	170-045-330	Capscrew, Hex 5/16-18 x 1.25 (ss)	24
11	171-017-115	Capscrew, Flat Socket Head 1/4-20 x .50	4
	171-017-330	Capscrew, Flat Socket Head 1/4-20 x .50	4
12	171-076-115	Capscrew, Flanged 1/4- 20 x 75	4
	171-076-330	Capscrew, Flanged 1/4-20 x 75	4
13	171-077-115	Capscrew, Flanged 1/4-20 x 1.50	4
	171-077-330	Capscrew, Flanged 1/4-20 x 1.50	4
14	196-171-110	Chamber, Outer	2
	196-171-112	Chamber, Outer	2
	196-171-157	Chamber, Outer	2
15	286-095-354	Diaphragm	2
	286-095-356	Diaphragm	2
	286-095-360	Diaphragm	2
	286-095-363	Diaphragm	2
	286-095-364	Diaphragm	2
	286-095-365	Diaphragm	2
	286-116-000	Diaphragm, One-Piece Bonded	2
16	286-096-600	Diaphragm, Overlay	2
17	312-110-157	Elbow, Suction	2
18	312-111-157	Elbow, Discharge	2
19	360-099-360	Gasket, Spacer (used TPE Diaphragms only)	2
20	360-100-379	Gasket, Air Inlet	1

NOTE: See Pages 16 and 18 For Full Explanation of Air Valve Options.

ITEM	PART NUMBER	DESCRIPTION	QTY
21	360-102-360	Gasket, Air Valve	1
22	360-108-360	Gasket, Pilot Valve	1
23	518-157-157	Manifold (see item 29)	2
	518-157-157E	Manifold BSP Tapered (see item 29)	2
24	518-158-110	Manifold, Suction	1
	518-158-110E	Manifold, Suction BSP Tapered	1
	518-158-112	Manifold, Suction	1
	518-158-112E	Manifold, Suction BSP Tapered	1
25	518-159-110	Manifold, Discharge	1
	518-159-110E	Manifold, Discharge BSP Tapered	1
	518-159-112	Manifold, Discharge	1
	518-159-112E	Manifold, Discharge BSP Tapered	1
26	530-035-000	Metal Muffler	1
27	545-004-115	Nut, Hex Flanged 5/16-18 (Aluminum)	24
	545-004-330	Nut, Hex Flanged 5/16-18 (Aluminum)	24
	545-004-115	Nut, Hex Flanged 5/16-18 (Stainless Steel)	8
	545-004-330	Nut, Hex Flanged 5/16-18 (Stainless Steel)	8
28	560-001-360	O-ring	2
29	560-083-360	O-ring (Aluminum Manifold)	4
	560-083-363	O-ring (Aluminum Manifold)	4
	560-083-364	O-ring (Aluminum Manifold)	4
	560-083-365	O-ring (Aluminum Manifold)	4
	720-064-600	Seal (Aluminum Manifold)	4
	560-083-360	O-ring (metallic seats only)	8
	560-083-363	O-ring (metallic seats only)	8
	560-083-364	O-ring (metallic seats only)	8
	560-083-365	O-ring (metallic seats only)	8
	560-083-611	O-ring (metallic seats only)	8
30	612-091-110	Plate, Outer Diaphragm	2
	612-091-112	Plate, Outer Diaphragm	2
	612-091-157	Plate, Outer Diaphragm	2
31	612-177-330	Plate, Inner Diaphragm	2
	612-221-330	Plate, Inner Diaphragm (One-Piece Bonded Only)	2
32	620-019-115	Plunger, Actuator	2
33	675-042-115	Ring, Retainer	1
34	685-056-120	Rod, Diaphragm	2
35	720-012-360	Seal, U-Cup Shaft	4
36	722-094-080	Seat, Check Valve (item 29 required)	4
	722-094-110	Seat, Check Valve (item 29 required)	4
	722-094-150	Seat, Check Valve (item 29 required)	4
	722-094-550	Seat, Check Valve	4
	722-094-600	Seat, Check Valve	4
37	900-004-115	5/16 Lock Washer (Aluminum)	48
	900-004-330	5/16 Lock Washer (Aluminum)	48
	900-004-115	5/16 Lock Washer (Stainless Steel)	32
	900-004-330	5/16 Lock Washer (Stainless Steel)	32



Note: Atex Compliant

Distribution Valve Assembly Drawing

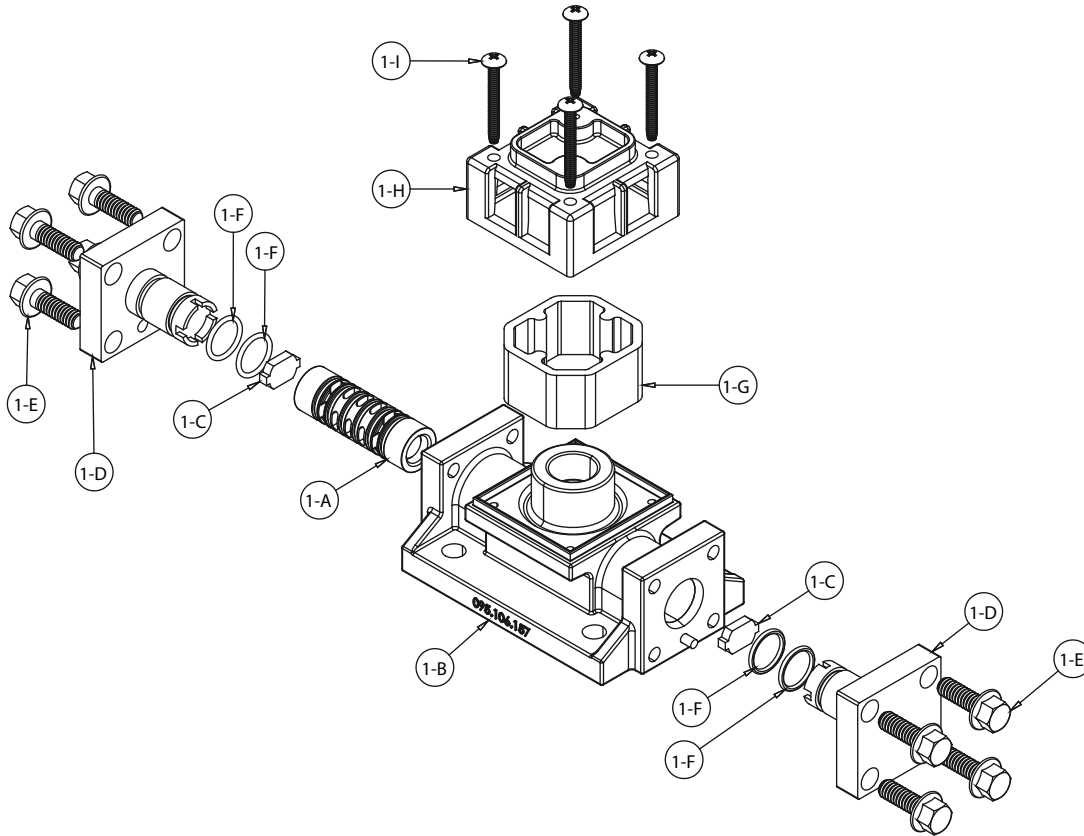

MAIN AIR VALVE ASSEMBLY PARTS LIST			
ITEM	PART NUMBER	DESCRIPTION	QTY
★ 1	031-191-000	Valve Assembly	1
1-A	031-132-000	Sleeve and Spool Set	1
1-B	095-106-157	Valve Body	1
1-C	132-038-357	Bumper	2
1-D	165-128-157	End Cap	2
1-E	171-076-330	Hex Flange Capscrew 1/4-20 x .75	8
1-F	560-101-360	O-ring	4
1-G	530-031-550	Muffler	1
1-H	165-109-551	Muffler Cap	1
1-I	706-027-330	Machine Screw	4

MAIN AIR VALVE ASSEMBLY PARTS LIST			
ITEM	PART NUMBER	DESCRIPTION	QTY
★ 1	031-191-003	Valve Assembly	1
(same as above 031-191-003 except items 1-E, and 1-I)			
1-E	171-076-115	Hex Flange Capscrew 1/4-20 x .75	8
1-I	706-027-115	Machine Screw	4

MAIN AIR VALVE ASSEMBLY PARTS LIST			
ITEM	PART NUMBER	DESCRIPTION	QTY
▲ 1	031-186-000	Valve Assembly	1
(Same as above 031-191-000 minus items 1-G, 1-H, and 1-I)			

MAIN AIR VALVE ASSEMBLY PARTS LIST			
ITEM	PART NUMBER	DESCRIPTION	QTY
▲ 1	031-186-003	Valve Assembly	1
(Same as above 031-186-003 except item 1-E)			
1-E	171-076-115	Hex Flange Capscrew 1/4-20 x .75	8

★ NOTE: Pumps equipped with integral mufflers are not ATEX compliant.

▲ NOTE: Pumps equipped with this valve assembly are ATEX compliant when a metal muffler is used.

 Note: ATEX Compliant

AIR DISTRIBUTION VALVE SERVICING

To service the air valve first shut off the compressed gas, bleed pressure from the pump, and disconnect the air supply line from the pump.

Step #1: See COMPOSITE REPAIR PARTS DRAWING.

Using a 3/8" wrench or socket, remove the four hex capscrews (items 12). Remove the gas valve assembly from the pump.

Remove and inspect gasket (item 21) for cracks or damage. Replace gasket if needed.

Step #2: Disassembly of the air valve.

Using a 3/8" wrench or socket, remove the eight hex capscrews (items 1-E) that fasten the end caps to the valve body. Next remove the two end caps (items 1-D). Inspect the two o-rings (items 1-F) on each end cap for damage or wear. Replace the o-rings as needed.

Remove the bumpers (items 1-C). Inspect the bumpers for damage or wear. Replace the bumpers as needed.

Remove the spool (part of item 1-A) from the sleeve. Be careful not to scratch or damage the outer diameter of the spool. Wipe spool with a soft cloth and inspect for scratches or wear.

Inspect the inner diameter of the sleeve (part of item 1-A) for dirt, scratches, or other contaminants. Remove the sleeve if needed and replace with a new sleeve and spool set (item 1-A).

Step #3: Reassembly of the air valve.

Install one bumper (item 1-C) and one end cap (item 1-D), with two o-rings (items 1-F), and fasten with four hex capscrews (items 1-E) to the valve body (item 1-B). Align hole in end cap with roll pin on valve body.

Remove the new sleeve and spool set (item 1-A) from the plastic bag. Carefully remove the spool from the sleeve. Install the six o-rings (item 1-F) into the six grooves on the sleeve. Apply a light coating of grease to the o-rings before installing the sleeve into the valve body (item 1-B), align the slots in the sleeve with the slots in the valve body. Insert the spool into the sleeve. Be careful not to scratch or damage the spool during installation. Install the remaining bumper and end cap (with o-rings), and fasten with the remaining hex capscrews. Align hole in end cap with roll pin on valve body.

Fasten the air valve assembly (item 1) and gasket to the pump. Connect the compressed air line to the pump. The pump is now ready for operation.



! IMPORTANT

Read these instructions completely, before installation and start-up. It is the responsibility of the purchaser to retain this manual for reference. Failure to comply with the recommendations stated in this manual will damage the pump, and void factory warranty.

Air Valve with Stroke Indicator Assembly Drawing, Parts List

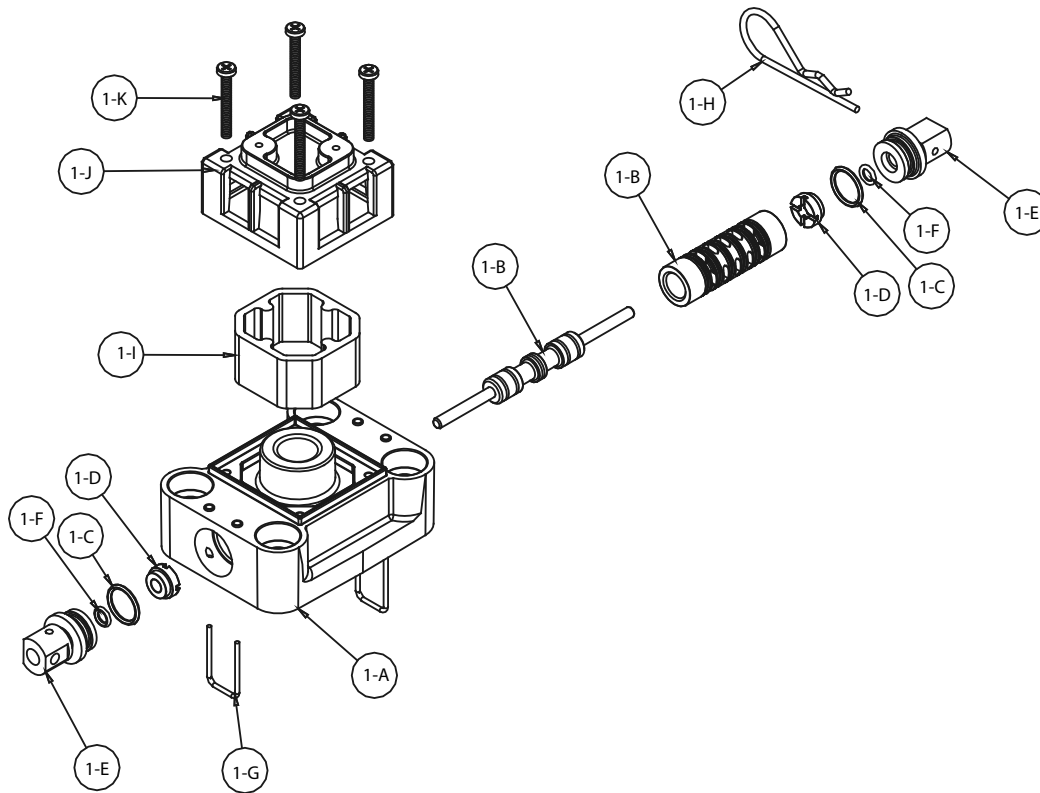

MAIN AIR VALVE ASSEMBLY PARTS LIST

Item	Part Number	Description	Qty
▲ 1	031-167-000	Air Valve Assembly	1
1-A	095-106-559	Body, Air Valve	1
1-B	031-134-000	Sleeve and Spool Set	1
1-C	560-101-360	O-Ring	8
1-D	132.030.552	Bumper	2
1-E	165-123-147	End Cap	2
1-F	560-029-360	O-Ring	2
1-G	675-062-115	End Cap Retainer	2
1-H	210-008-330	Safety Clip	1
1-I	530-031-550	Muffler	1
1-J	165-109-559	Muffler Cap	1
1-K	710-011-115	Self-Tapping Screw	4

For Pumps with Virgin PTFE coated hardware:

1	031-167-002	Air Valve Assembly	1
1-G	675-062-308	End Cap Retainer	2
1-J	710-011-308	Self Tapping Screw	4

(Includes all other items used on 031-166-000 above)

For Pumps with alternate Mesh Muffler or Piped Exhaust:

▲ 1	031-169-000	Air Valve Assembly	1
-----	-------------	--------------------	---

(Includes all items used on 031-167-000 above minus 1-H, 1-I and 1-J)



▲ Note: Atex Compliant

AIR DISTRIBUTION VALVE WITH STROKE INDICATOR OPTION SERVICING

To service the air valve first shut off the compressed air, bleed pressure from the pump, and disconnect the air supply line from the pump.

STEP #1: See COMPOSITE REPAIR PARTS DRAWING.

Using a 3/8" wrench or socket, remove the four hex flanged capscrews (item 12). Remove the air valve assembly from the pump.

STEP #2: Disassembly of the air valve.

To access the internal air valve components first remove the two end cap retainers (item 1-G) by inserting a small flat screwdriver into the two slotted grooves on the valve body and gently lifting the retainers out.

Next remove the two end caps (item 1-E) by grasping the pull tab with finger and thumb or pliers and tugging. Inspect the two o-rings (items 1-C and 1-F) on each end cap for wear or cuts. Replace the o-rings if necessary.

Remove the spool (part of item 1-B) from the sleeve. Be careful not to scratch or damage the outer diameter of the spool. Wipe spool with a soft clean cloth and inspect for scratches or abrasive wear.

Inspect the inner diameter of the sleeve (part of item 1-B) for dirt, scratches, or other contaminants. Remove the sleeve if needed and replace with a new sleeve and spool set (item 1-B). **Note:** The sleeve and spool set is match-ground to a specified clearance. Sleeves and spools cannot be interchanged.

STEP #3: Reassembly of the air distribution valve.

Install one end cap with o-rings (items 1-E, 1-C, and 1-F) into one end of the air valve body (item 1-A). Insert one end cap retainer (item 1-G) into the two smaller holes, align with groove in the end cap, and push until the closed end of the retainer is below the flat surface of the valve body.

Remove the new sleeve and spool set (item 1-B) from the plastic bag. Carefully remove the spool from the sleeve. Install the six o-rings (item 1-C) into the six grooves on the sleeve. Apply a light coating of grease to the o-rings before installing the sleeve into the valve body. Align the slots in the sleeve with the slots in the valve body. Insert the spool into the sleeve. Be careful not to scratch or damage the spool during installation. Push the spool in until the pin touches the end cap on the opposite end.

Install the remaining end cap with o-rings and retainer.

Fasten the air valve assembly (item 1) and gasket (item 23) to the pump, using the four hex flanged capscrews (item 12).

Connect the compressed air line to the pump. The pump is now ready for operation.

IMPORTANT: Remove the safety clip. The pump will not function properly until it is removed. The pump is now ready for operation.



! IMPORTANT

Read these instructions completely, before installation and start-up. It is the responsibility of the purchaser to retain this manual for reference. Failure to comply with the recommendations stated in this manual will damage the pump, and void factory warranty.

Solenoid Shifted Air Valve Drawing

SOLENOID SHIFTED AIR VALVE PARTS LIST

(Includes all items used on Composite Repair Parts List except as shown)

ITEM	PART NUMBER	DESCRIPTION	QTY
4	114-023-157	Bracket, Intermediate	1
38	893-099-000	Solenoid Valve, NEMA4	1
39	219-001-000	Solenoid Coil, 24VDC	1
	219-004-000	Solenoid Coil, 24VAC/12VDC	1
	219-002-000	Solenoid Coil, 120VAC	1
	219-003-000	Solenoid Coil, 240VAC	1
40	241-001-000	Connector, conduit	1
	241-003-000	Conduit Connector with Suppression Diode (DC Only)	1
41	171-065-115	Capscrew, Flanged ¼-20 x 1.00	4
42	618-050-150	Plug (Replaces Item 7)	2



IEC EEx m T4



△ For Explosion Proof Solenoid Coils used in North America and outside the European Union.

39	219-009-001	Solenoid Coil, 120VAC 60 Hz	1
	219-009-002	Solenoid Coil, 240VAC 60 Hz	1
	219-009-003	Solenoid Coil, 12VDC	1
	219-009-004	Solenoid Coil, 24VDC	1
	219-009-005	Solenoid Coil, 110VAC 50 Hz	1
	219-009-006	Solenoid Coil, 230VAC 50 Hz	1

Note: Item 40 (Conduit Connector) is not required



II 2G EEx m c T5
II 2D c IP65 T100°C

***◆ For Explosion Proof Solenoid Coils used in the European Union**

39	219-011-001	Solenoid Coil, 12 VDC, 3.3W / 0, 531A...0, 014A	1
	219-011-002	Solenoid Coil, 24 VDC, 3.3W / 0, 531A...0, 014A	1
	219-011-003	Solenoid Coil, 110/120 VAC, 3.4W / 0, 212A...0, 015A	1
	219-011-004	Solenoid Coil, 220/240 VAC, 3.4W / 0, 212A...0, 015A	1

Note: Item 40 (Conduit Connector) is not required

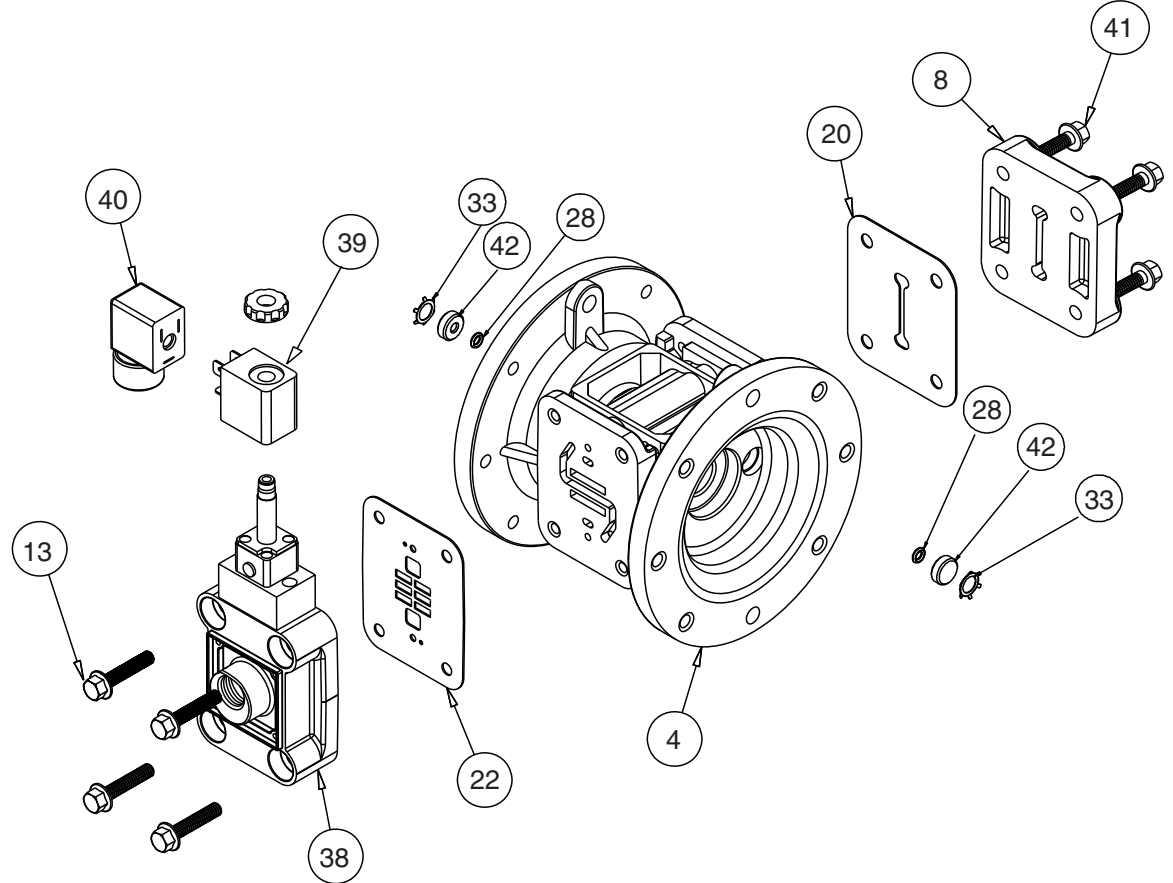

*Special Conditions For Safe Use

A fuse corresponding to its rated current (max. $3 \cdot I_{rat}$ according IEC 60127-2-1) or a motor protecting switch with short-circuit and thermal instantaneous tripping (set to rated current) shall be connected in series to each solenoid as short circuit protection. For very low rated currents of the solenoid the fuse of lowest current value according to the indicated IEC standard will be sufficient. The fuse may be accommodated in the associated supply unit or shall be separately arranged. The rated voltage to the fuse shall be equal to or greater than the stated rated voltage of the magnet coil. The breakage capacity of the fuse-link shall be as high as or higher than the maximum expected short circuit current at the location of the installation (usually 1500 A). A maximum permissible ripple of 20% is valid for all magnets of direct-current design.

SOLENOID SHIFTED AIR DISTRIBUTION VALVE OPTION

Warren Rupp's solenoid shifted, air distribution valve option utilizes electrical signals to precisely control your SANDPIPER's speed. The solenoid coil is connected to a customer - supplied control. Compressed air provides the pumping power, while electrical signals control pump speed (pumping rate).

OPERATION

The Solenoid Shifted SANDPIPER has a solenoid operated, air distribution valve in place of the standard SANDPIPER's pilot operated, air distribution valve. Where a pilot valve is normally utilized to cycle the pump's air distribution valve, an electric solenoid is utilized. As the solenoid is powered, one of the pump's air chambers is pressurized while the other chamber is exhausted. When electric power is turned off, the solenoid shifts and the pressurized chamber is exhausted while the other chamber is pressurized. By alternately applying and removing power to the solenoid, the pump cycles much like a standard SANDPIPER pump, with one exception. This option provides a way to precisely control and monitor pump speed.

BEFORE INSTALLATION

Before wiring the solenoid, make certain it is compatible with your system voltage.

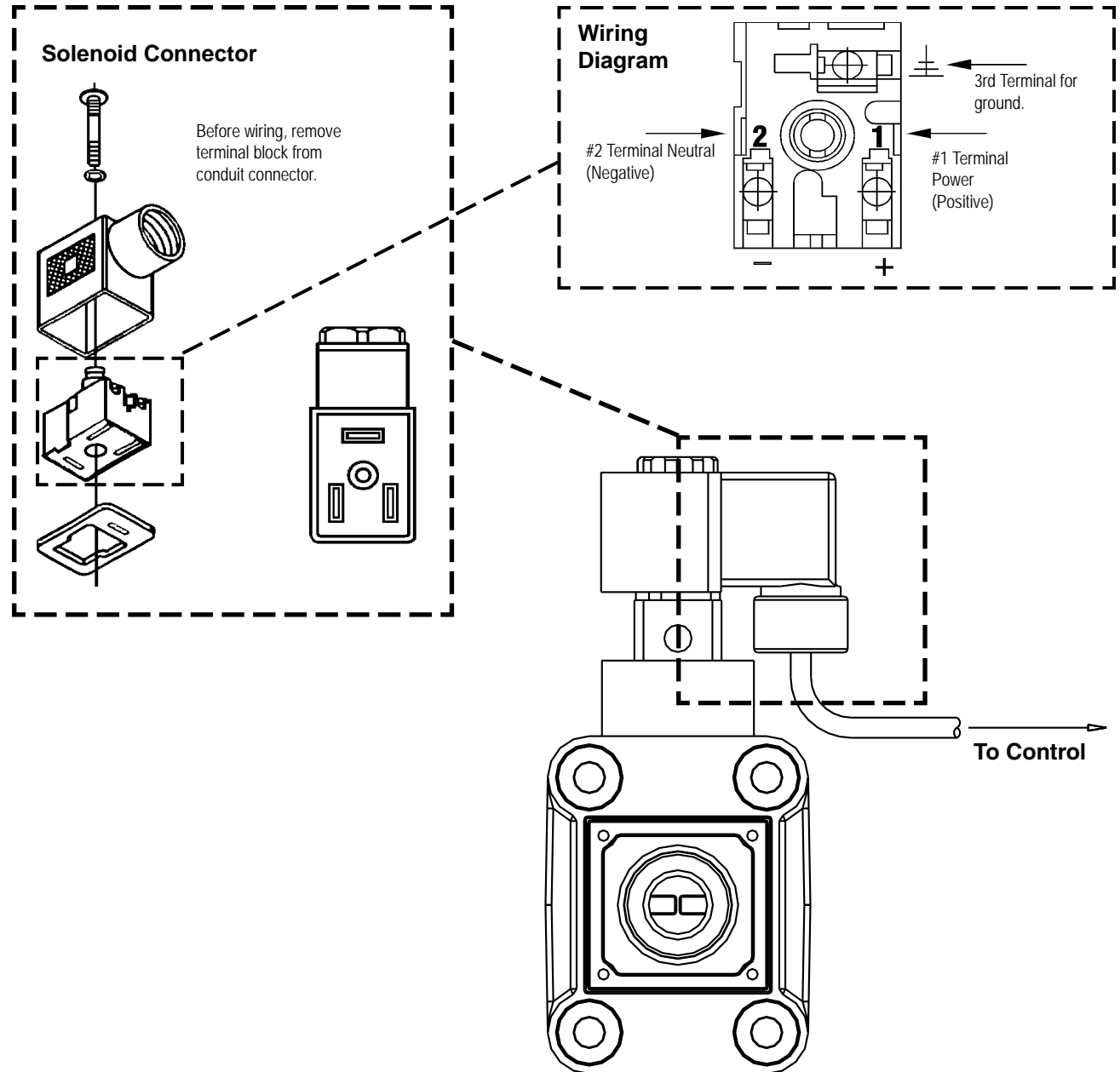

Diaphragm Service Drawing

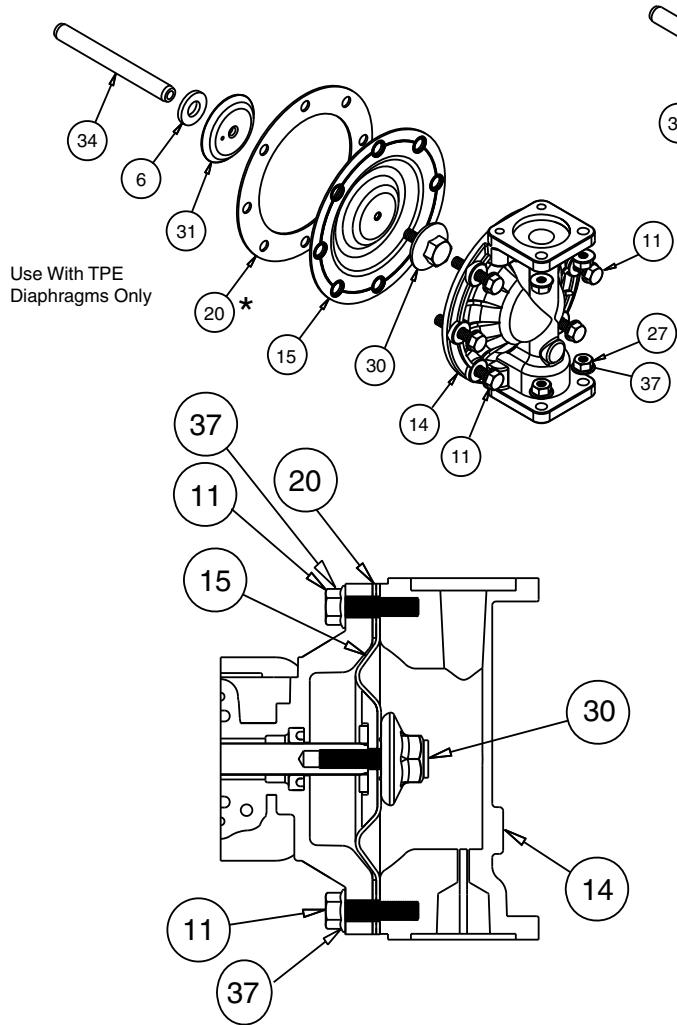

Diaphragm Orientation

Install diaphragm and spacer as shown above.

Diaphragm Service Drawing, with Overlay

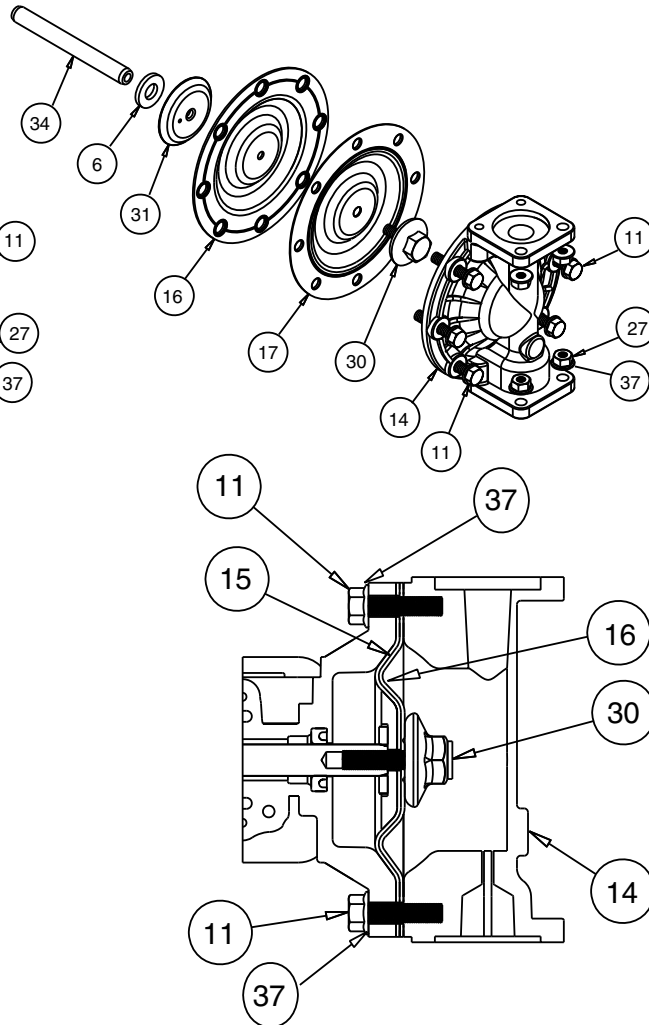

Diaphragm Orientation

Install diaphragm and overlay as shown above.

Diaphragm Service for One-Piece Bonded

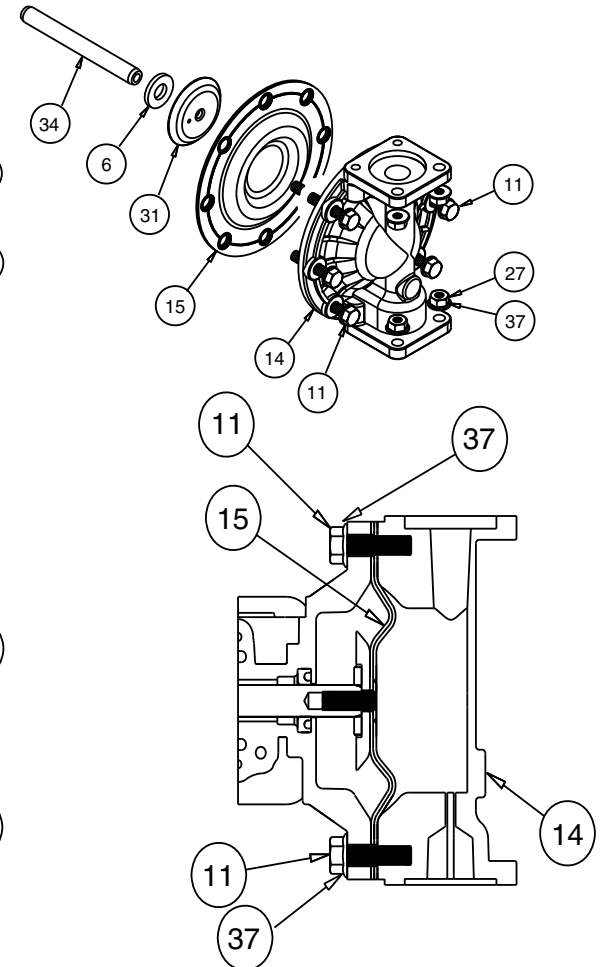

Diaphragm Orientation

Install diaphragm (286-116-000 only) as shown above.

DIAPHRAGM SERVICING

To service the diaphragm first shut off the suction, then shut off the discharge lines to the pump. Shut off the compressed air supply, bleed the pressure from the pump, and disconnect the air supply line from the pump. Drain any remaining liquid from the pump.

Step #1: See the pump composite repair parts drawing, and the diaphragm servicing illustration.

Using a 1/2" wrench or socket, remove 8 capscrews (items 9 & 10), washers and nuts that fasten the discharge elbows (item 18) or the discharge manifold (item 25). Remove the elbows and manifold assembly (items 18 & 23) or manifold (item 25). Use the same procedure to remove the suction elbows (item 17) or suction manifold (item 24).

Step #2: Removing the outer chambers. Using a 1/2" wrench or socket, remove the 16 capscrews (item 10), washers that fasten the outer chambers (item 14), diaphragms (items 15 & 16) and intermediate bracket (item 4) together.

Step #3: Removing the diaphragm assemblies.

Use a 3/4" (19mm) wrench or six pointed socket to remove the diaphragm assemblies (outer plate, diaphragm, and inner plate) from the diaphragm rod (item 34) by turning counterclockwise.

Insert a 6-32 set screw into the smaller tapped hole in the inner

diaphragm plate (item 31). Insert the protruding stud and the 6-32 fastener loosely into a vise. Use a 3/4" wrench or socket to remove the outer diaphragm plate (item 30) by turning counterclockwise. Inspect the diaphragm (item 15 & 16) for cuts, punctures, abrasive wear or chemical attack. Replace the diaphragms if necessary.

Step #4: Installing the diaphragms.

Push the threaded stud of the outer diaphragm plate through the center hole of the diaphragm. Thread the inner plate clockwise onto the stud. Insert the loose assembly with the above 6-32 fastener back into the vise. Use a torque wrench to tighten the diaphragm assembly together to 7.5 ft. Lbs. (10.17 Newton meters). Allow a minimum of 15 minutes to elapse after torquing, then re-torque the assembly to compensate for stress relaxation in the clamped assembly.

Step #5: Installing the diaphragm assemblies to the pump.

Make sure the bumper (item 6) is installed over the diaphragm rod.

Thread the stud of the one diaphragm assembly clockwise into the tapped hole at the end of the diaphragm rod (item 34) until the inner diaphragm plate is flush to the end of the rod. Insert rod into pump.

Align the bolt holes in the diaphragm with the bolt pattern in the intermediate (item 4).

Fasten the outer chamber (item 14) to the pump, using the capscrews (item 10) washers.

On the opposite side of the pump, pull the diaphragm rod out as far as possible. Make sure the bumper (item 6) is installed over the diaphragm rod.

Thread the stud of the remaining diaphragm assembly clockwise into the tapped hole at the end of the diaphragm rod (item 34) as far as possible and still allow for alignment of the bolt holes in the diaphragm with the bolt pattern in the inner chamber. Install diaphragms with convolutions facing towards center of pump. See sectional view on previous page.

Fasten the remaining outer chamber (item 14) to the pump, using the capscrews (item 10) and washers.

Step #6: Re-install the elbow/manifold assemblies to the pump, using the capscrews (items 9 and 10) washers and nuts.

The pump is now ready to be re-installed, connected and returned to operation.

OVERLAY DIAPHRAGM SERVICING

The overlay diaphragm (item 16) is designed to fit snugly over the exterior of the standard TPE diaphragm (item 15).

ONE-PIECE BONDED DIAPHRAGM SERVICING

The one-piece bonded diaphragm has a threaded stud installed in the integral plate at the factory. The inner diaphragm plate has a through hole instead of a threaded hole.

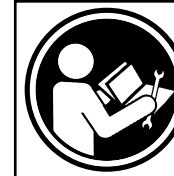

IMPORTANT

Read these instructions completely, before installation and start-up. It is the responsibility of the purchaser to retain this manual for reference. Failure to comply with the recommendations stated in this manual will damage the pump, and void factory warranty.

Place the inner plate over the diaphragm stud and thread the first diaphragm/inner plate into the diaphragm rod only until the inner plate contacts the rod. Do not tighten. A small amount of grease may be applied between the inner plate and the diaphragm to facilitate assembly.

Inside the first inner chamber push the pilot plunger pin all the way in, insert the first diaphragm/rod assembly into the pump and install the first outer chamber. Attach a regulated air line to the air inlet of the pump with the air pressure turned down to zero. Slowly begin turning up the air pressure until the diaphragm assembly completes one shift, enabling the second outer chamber to be installed.

Turn the pump over and thread the second diaphragm/inner plate onto the diaphragm rod. Turn the diaphragm until the inner plate contacts the rod and hand tighten the assembly. Continue tightening until the bolt holes align with eight inner chamber holes. **DO NOT LEAVE THE ASSEMBLY LOOSE.** Install the second outer chamber.

Pilot Valve Servicing, Assembly Drawing & Parts List

PILOT VALVE ASSEMBLY PARTS LIST

ITEM	PART NUMBER	DESCRIPTION	QTY
3	095-116-000	Pilot Valve Assembly	1
3-A	095-087-157	Valve Body	1
3-B	755-051-000	Sleeve (With O-rings)	1
3-C	560-033-360	O-ring (Sleeve)	6
3-D	775-055-000	Spool (With O-rings)	1
3-E	560-023-360	O-ring (Spool)	3
3-F	675-037-080	Retaining Ring	1

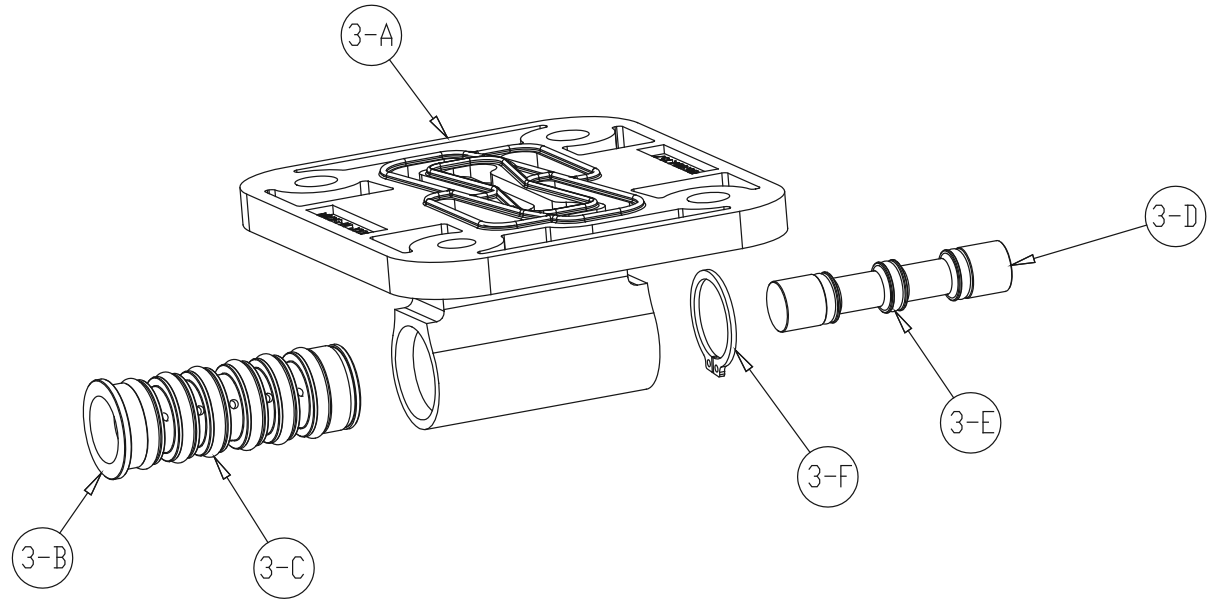

PILOT VALVE SERVICING

To service the pilot valve first shut off the compressed air supply, bleed the pressure from the pump, and disconnect the air supply line from the pump.

STEP #1: See pump assembly drawing.

Using a 7/16" wrench or socket, remove the four capscrews (item 13). Remove the air inlet cap (item 8) and air inlet gasket (item 20). The pilot valve assembly (item 3) can now be removed for inspection and service.

STEP #2: Disassembly of the pilot valve.

Remove the pilot valve spool (item 3-D). Wipe clean and inspect spool and o-rings for dirt, cuts or wear. Replace the o-rings and spool if necessary.

Remove the retaining ring (item 3-F) from the end of the sleeve (item 3-B) and remove the sleeve from the valve body (item 3-A). Wipe clean and inspect sleeve and o-rings for dirt, cuts or wear. Replace the o-rings and sleeve if necessary.

STEP #3: Re-assembly of the pilot valve.

Generously lubricate outside diameter of the sleeve and o-rings. Then carefully insert sleeve into valve body. Take CAUTION when inserting sleeve, not to shear any o-rings. Install retaining ring to sleeve. Generously lubricate outside diameter of spool and o-rings. Then carefully insert spool into sleeve. Take CAUTION when inserting spool, not to shear any o-rings. Use BP-LS-EP-2 multipurpose grease, or equivalent.

STEP #4: Re-install the pilot valve assembly into the intermediate.

Be careful to align the ends of the pilot valve stem between the plunger pins when inserting the pilot valve into the cavity of the intermediate.

Re-install the gasket, air inlet cap and capscrews. Connect the air supply to the pump. The pump is now ready for operation.

Intermediate Assembly Drawing

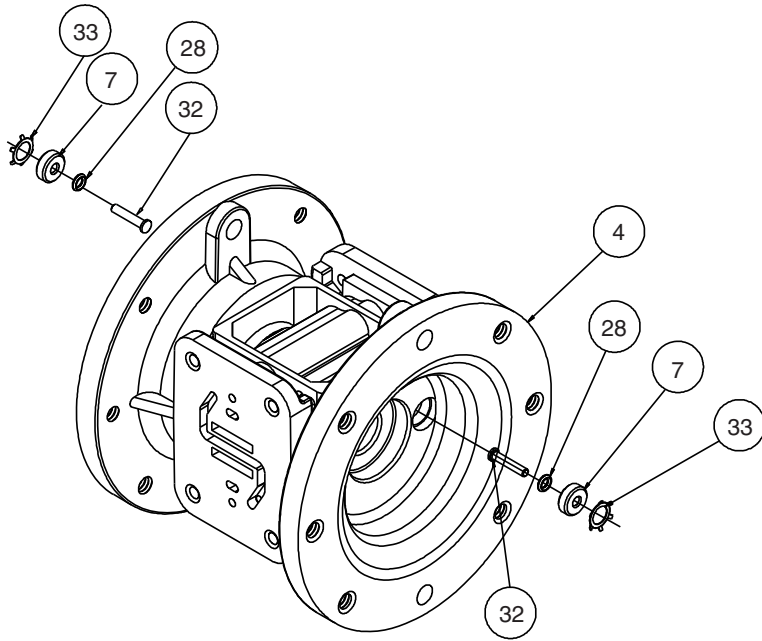

INTERMEDIATE REPAIR PARTS LIST

ITEM	PART NUMBER	DESCRIPTION	QTY
4	114-023-157	Bracket, Intermediate	1
7	135-036-506	Bushing, Plunger	2
28	560-001-360	O-Ring	2
32	620-019-115	Plunger, Actuator	2
33	675-042-115	Ring, Retaining*	2

***NOTE:** It is recommended that when plunger components are serviced, new retaining rings be installed.

Intermediate Assembly Servicing

ACTUATOR PLUNGER SERVICING

To service the actuator plunger first shut off the compressed air supply, bleed the pressure from the pump, and disconnect the air supply line from the pump.

Step #1: See PUMP ASSEMBLY DRAWING.

Using a 3/8" wrench or socket, remove the four capscrews (items 12). Remove the air inlet cap (item 8) and air inlet gasket (item 20). The pilot valve assembly (item 3) can now be removed.

Step #2: Servicing the actuator plungers.

See PUMP ASSEMBLY DRAWING.

The actuator plungers (items 32) can be reached through the stem cavity of the pilot valve in the intermediate bracket (item 4). To service bushings, o-rings and retaining rings, see Intermediate Drawing.

Remove the plungers (items 32) from the bushings (item 7) in each end of the intermediate cavity. Inspect for wear or damage. Replace plunger as needed. Apply a light coating of grease to each o-ring and re-install the plungers in to the bushings. Push the plungers in as far as they will go.

Step #3: Re-install the pilot valve assembly into the intermediate assembly.

Be careful to align the ends of the stem between the plungers when inserting the stem of the pilot valve into the cavity of the intermediate.

Re-install the gasket (item 20), air inlet cap (item 8) and capscrews (items 12).

Connect the air supply to the pump. The pump is now ready for operation.

PLUNGER BUSHING, O-RING, AND RETAINING RING SERVICING

To service the plunger bushing components first remove the two retaining rings (items 33) using a small flat screwdriver. ***Note:** It is recommended that new retaining rings be installed.

Next remove the two plunger bushings (items 7). Inspect the bushings for wear or scratches. Replace the bushings as necessary.

Inspect the two o-rings (28) for cuts and/or wear.



! IMPORTANT

Read these instructions completely, before installation and start-up. It is the responsibility of the purchaser to retain this manual for reference. Failure to comply with the recommendations stated in this manual will damage the pump, and void factory warranty.

CHECK VALVE SERVICING

Before servicing the check valve components, first shut off the suction line and then the discharge line to the pump. Next, shut off the compressed air supply, bleed air pressure from the pump, and disconnect the air supply line from the pump. Drain any remaining fluid from the pump. The pump can now be removed for service.

To access the check valve components, remove the manifold/manifold assembly. Use a 1/2" wrench or socket to remove the fasteners. Once the manifold is removed, the check valve components can be seen.

Inspect the check balls (items 2) for wear, abrasion, or cuts on the spherical surface. The check valve seats (item 36) should be inspected for cuts, abrasive wear, or embedded material on the surfaces of both the external and internal chambers. The spherical surface of the check balls must seat flush to the surface of the check valve seats for the pump to operate to peak efficiency. Replace any worn or damaged parts as necessary.

Re-assemble the check valve components. The seat should fit into the counter bore of the outer chamber.

The pump can now be reassembled, reconnected and returned to operation.

METALLIC SEATS

Two o-rings (or conductive PTFE seals) (item 29) are required for metallic seats.

Check Valve Drawing

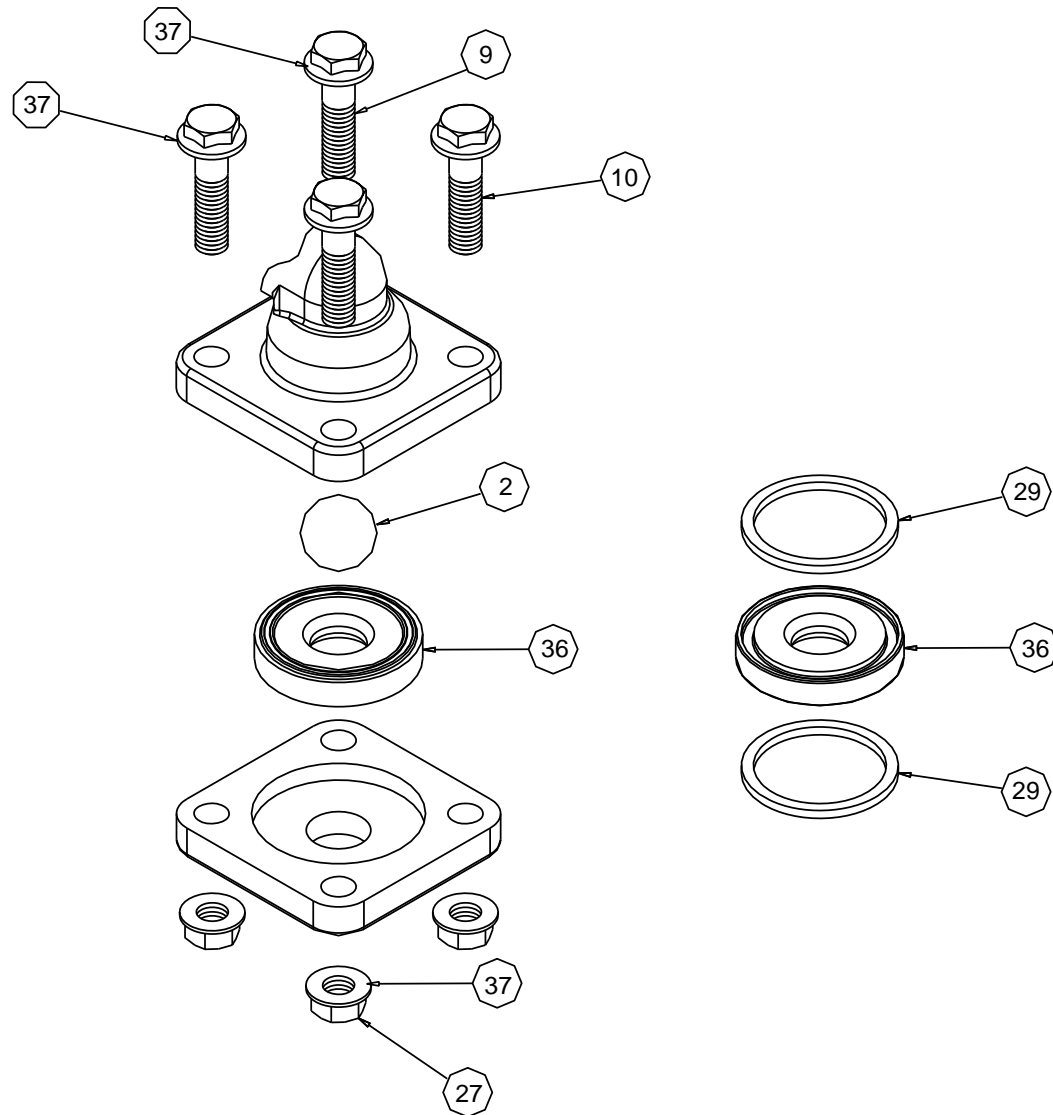

Optional Muffler Configurations, Drawing

OPTION 0

530-031-550 Integral Muffler uses (1) Cap and (4) 706-027-115 Machine Screw to hold it in place.

OPTION 1

530-024-000 Sound Dampening Muffler screws directly into the Air Valve body. This muffler is equipped with a porous plastic element.

OPTION 2

530-023-000 Mesh Muffler screws directly into the Air Valve Body. This muffler is equipped with a metal element.



OPTION 6

530-035-000 Metal Muffler screws directly into the Air Body.

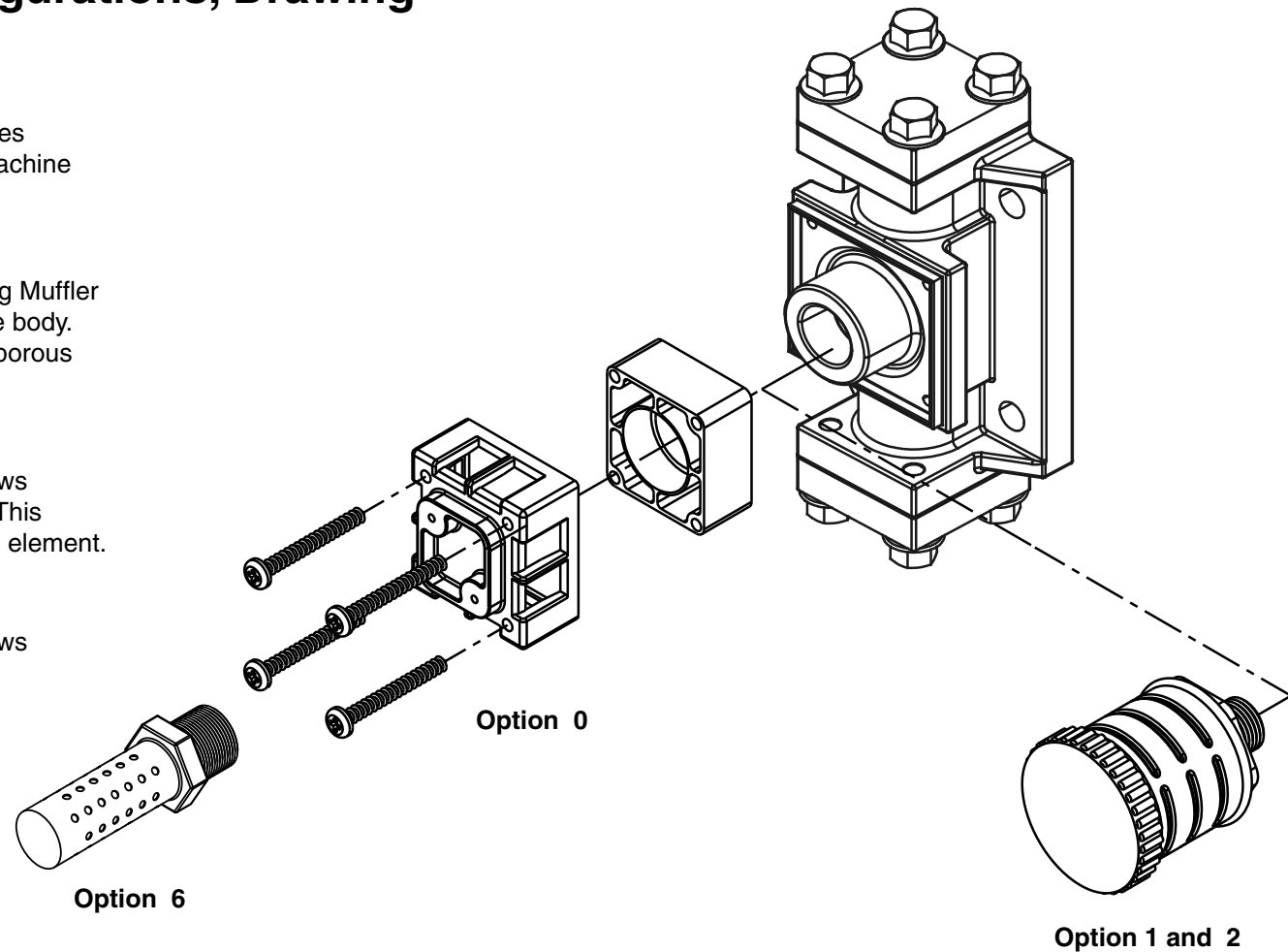

Note: ATEX compliant

Dual Port Option Drawing (Aluminum Model Only)

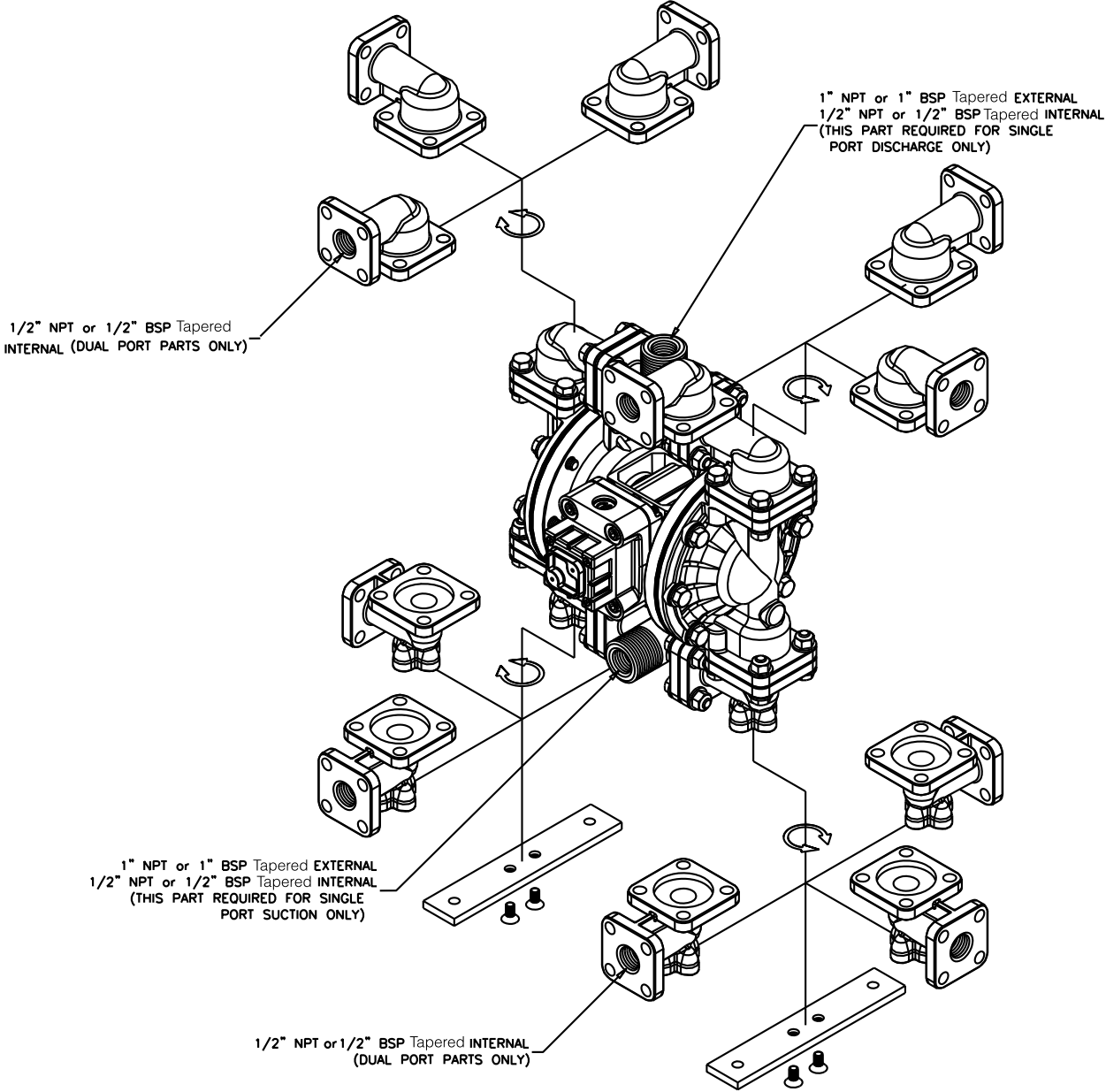

DUAL PORTING OPTIONS

Several dual porting options are possible. The pump can be converted to a dual port arrangement on both the suction and the discharge ends. The porting can be configured to a single suction and a dual discharge. The porting can be changed to a dual suction and a single discharge.

The above changes are possible because the porting flange of the elbows (items 19) are designed to mate with 1/2" NPT or BSP (Tapered) connection.

DUAL PORTING OF BOTH SUCTION AND DISCHARGE ENDS OF THE PUMP

Converting the pump from the standard single suction and discharge porting configuration to dual porting at each end is easy. Simply remove the manifold seals and manifolds (items 24 and 29 from pump assembly drawing) from the pump.

The discharge elbows and suction elbows can be rotated 90° increments (see arrows and optional positioning in the Dual Port Options Drawing.)

SINGLE PORTING OF THE SUCTION AND DUAL PORTING OF THE PUMP DISCHARGE

To convert the pump from the standard single suction and single discharge porting configuration to a dual discharge porting arrangement remove the only the discharge manifolds and manifold seals. Position the discharge elbows in the desired direction at 90° increments. (See arrows and optional positioning in the Dual Porting Drawing.)

DUAL PORTING OF THE SUCTION AND SINGLE PORTING OF THE PUMP DISCHARGE

To convert the pump from the standard single suction and single discharge porting configuration to a dual suction porting arrangement remove the only the suction (bottom) manifolds and manifold seals.

Position the suction elbows in the desired direction at 90° increments. (See arrows and optional positioning in the Dual Porting Drawing.)

NOTE: See Repair Parts Lists on next page.



! IMPORTANT

Read these instructions completely, before installation and start-up. It is the responsibility of the purchaser to retain this manual for reference. Failure to comply with the recommendations stated in this manual will damage the pump, and void factory warranty.

SINGLE PORT SUCTION REPAIR PARTS LIST

ITEM	PART NO.	DESCRIPTION	QTY
10*	170-045-115	Capscrew, Hex 5/16-18 x 1.25	32
	170-045-330	Capscrew, Hex 5/16-18 x 1.25	32
18*	312-111-157E	Elbow, Discharge BSP (tapered) (replaces 312-111-157)	2
	312-111-157N	Elbow, Discharge 1/2" NPT (replaces 312-111-157)	2
23*	518-157-157	Manifold BSPT (suction position only)	1
	518-157-157E	Manifold NPT (suction position only)	1
27*	545-004-115	Nut, Hex 5/16-18	28
	545-004-330	Nut, Hex 5/16-18	28
29*	560-083-360	O-ring (Alum Manifold)	2
	560-083-363	O-ring (Alum Manifold)	2
	560-083-364	O-ring (Alum Manifold)	2
	560-083-365	O-ring (Alum Manifold)	2
	720-064-600	Seal (Alum Manifold)	2
37*	900-004-115	Lock Washer	40
	900-004-330	Lock Washer	40

SINGLE PORT DISCHARGE REPAIR PARTS LIST

10*	170-045-115	Capscrew, Hex 5/16-18 X 1.25	32
	170-045-330	Capscrew, Hex 5/16-18 X 1.25	32
17*	312-110-157E	Elbow, Suction BSP (tapered) (replaces 312-110-157)	2
	312-110-157N	Elbow, Suction 1/2" NPT (replaces 312-110-157)	2
23*	518-157-157	Manifold BSPT (discharge position only)	1
	518-157-157E	Manifold NPT (discharge position only)	1
27*	545-004-115	Nut, Hex 5/16-18	28
	545-004-330	Nut, Hex 5/16-18	28
29*	560-083-360	O-ring (Alum Manifold)	2
	560-083-363	O-ring (Alum Manifold)	2
	560-083-364	O-ring (Alum Manifold)	2
	560-083-365	O-ring (Alum Manifold)	2
	720-064-600	Seal (Alum Manifold)	2
37*	900-004-115	Lock Washer	40
	900-004-330	Lock Washer	40

DUAL PORT SUCTION AND DISCHARGE REPAIR PARTS LIST

10*	170-045-115	Capscrew, Hex 5/16-18 X 1.25	24
	170-045-330	Capscrew, Hex 5/16-18 X 1.25	24
17*	312-110-157E	Elbow, Suction BSP (tapered) (replaces 312-110-157)	2
	312-110-157N	Elbow, Suction 1/2" NPT (replaces 312-110-157)	2
18*	312-111-157E	Elbow, Discharge BSP (tapered) (replaces 312-111-157)	2
	312-111-157N	Elbow, Discharge 1/2" NPT (replaces 312-111-157)	2
23*	518-157-157	Manifold (not required)	0
27*	545-004-115	Nut, Hex 5/16-18	20
	545-004-330	Nut, Hex 5/16-18	20
29*	560-083-360	O-ring (Alum Manifold) (not required)	0
	560-083-363	O-ring (Alum Manifold) (not required)	0
	560-083-364	O-ring (Alum Manifold) (none required)	0
	560-083-365	O-ring (Alum Manifold) (none required)	0
	720-064-600	Seal (Alum Manifold) (none required)	0
37*	900-004-115	Lock Washer	32
	900-004-330	Lock Washer	32

*Quantities change from Composite Repair Parts List.

PUMPING HAZARDOUS LIQUIDS

When a diaphragm fails, the pumped liquid or fumes enter the air end of the pump. Fumes are exhausted into the surrounding environment. When pumping hazardous or toxic materials, the exhaust air must be piped to an appropriate area for safe disposal. See illustration #1 at right.

This pump can be submerged if the pump materials of construction are compatible with the liquid being pumped. The air exhaust must be piped above the liquid level. See illustration #2 at right. Piping used for the air exhaust must not be smaller than 1/2" (1.27 cm) diameter. Reducing the pipe size will restrict air flow and reduce pump performance. When the pumped product source is at a higher level than the pump (flooded suction condition), pipe the exhaust higher than the product source to prevent siphoning spills. See illustration #3 at right.

CONVERTING THE PUMP FOR PIPING THE EXHAUST AIR

The following steps are necessary to convert the pump to pipe the exhaust air away from the pump.

Use a Phillips screwdriver to remove the four self-tapping screws (item 1-H).

Remove the muffler cap and muffler (items 1-G and 1-F). The 3/8" NPT molded threads in the air distribution valve body (item 1-A).

Piping or hose may now be installed.

IMPORTANT INSTALLATION NOTE:

The manufacturer recommends installing a conductive flexible hose or connection between the pump and any rigid plumbing. This reduces stresses on the molded plastic threads of the air exhaust port. Failure to do so may result in damage to the air distribution valve body.

Any piping or hose connected to the pump's air exhaust port must be conductive and physically supported. Failure to support these connections could also result in damage to the air distribution valve body.

Exhaust Conversion Drawing

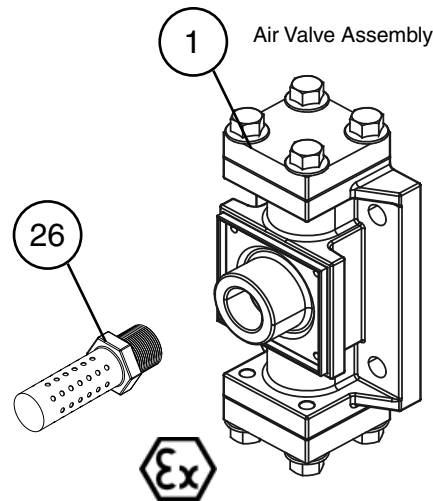

On ATEX compliant units the pump comes equipped with a metal muffler

CONVERTED EXHAUST ILLUSTRATION

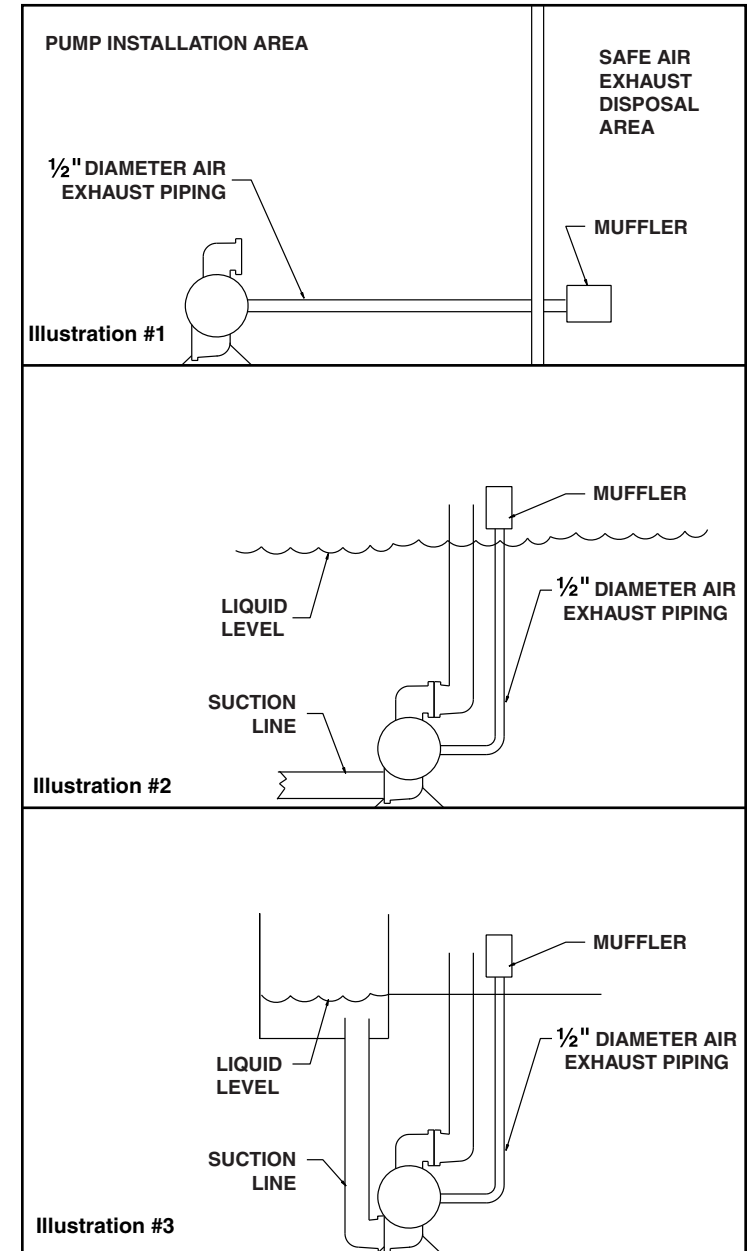

Pulse Output Kit Drawing

PULSE OUTPUT KIT OPTION

This pump can be fitted with a Pulse Output Kit. This converts the mechanical strokes of the pump to an electrical signal which interfaces with the Stroke Counter/ Batch Controller or user control devices such as a PLC.

The Pulse Output Kits mount directly onto the Muffler Cap on the Air Distribution Valve Assembly or onto the air valve and senses each stroke of the main spool.

Consult the factory for further information and availability.

Pulse Output Kits

475-244-001	10-30 VDC
475-244-002	110/220 VAC
475-244-003	10-30VDC, 110VAC and 220 VAC

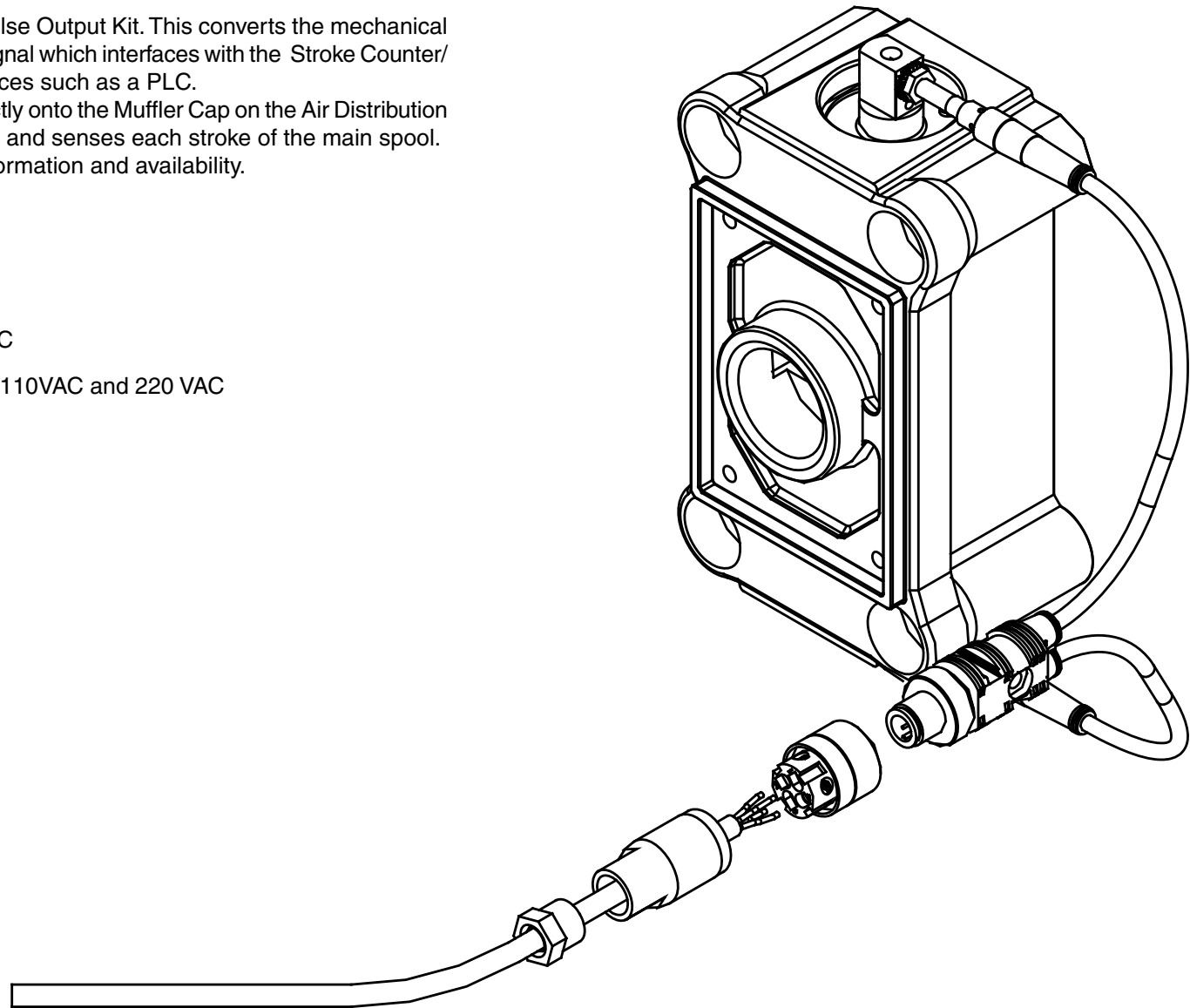

Grounding The Pump

To be fully groundable, the pumps must be ATEX Compliant. Refer to pump data sheet for ordering.

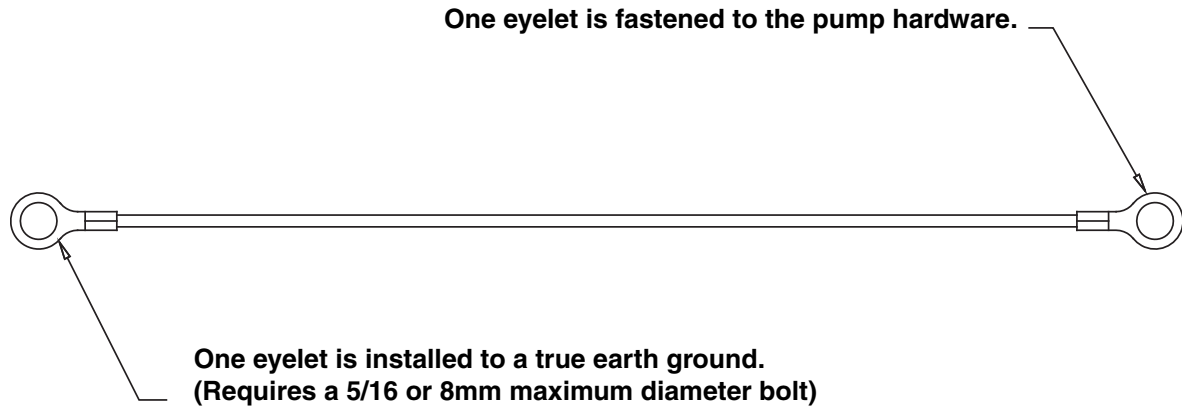

This 8 foot long (244 centimeters) Ground Strap, part number 920-025-000, can be ordered as a service item.

To reduce the risk of static electrical sparking, this pump must be grounded. Check the local electrical code for detailed grounding instruction and the type of equipment required.

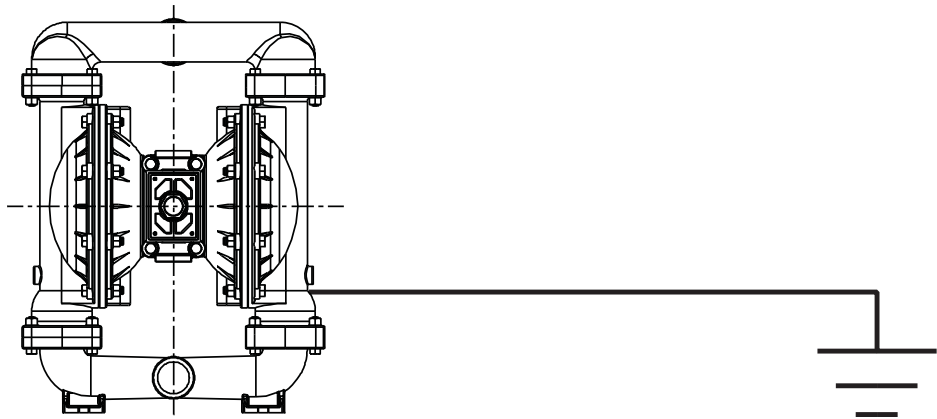

	! WARNING
	<i>Take action to prevent static sparking. Fire or explosion can result, especially when handling flammable liquids. The pump, piping, valves, containers or other miscellaneous equipment must be grounded.</i>

Declaration of Conformity



**WARREN
RUPP®**

IDEX
FLUID & METERING

Declaration of Conformity

Warren Rupp, Inc., 800 North Main Street, Mansfield, Ohio, certifies that Air-Operated Double Diaphragm Pumps Series: HDB, HDF, M Non-Metallic, S Non-Metallic, M Metallic, S Metallic, Containment Duty, Gas, UL, High Pressure, W, Submersible and Tranquilizers comply with the European Community Directive 98/37/EC, Safety of Machinery. This product has used EN 809, Pumps and Pump Units for Liquids - Common Safety Requirements harmonized standard to verify conformance.

David Roseberry

Signature of authorized person

October 20, 2005

Date of issue

David Roseberry

Printed name of authorized person

Engineering Manager

Title

CE



Declaration of Conformity