

Section	285
Page	285.1
Issue	C

FEATURES

Viking Classic+ (standard pump)		
①② Flow Range	GPM	To 650 GPM
	M ³ /Hr	To 150 M ³ /Hr
① Pressure Range	PSI	To 175 PSI
	BAR	To 12 BAR
① Temperature Range	°F	-22 to +350
	°C	-29 to +180
① Viscosity Range	SSU	to 500,000 SSU +
	cPs	to 110,000 cPs +

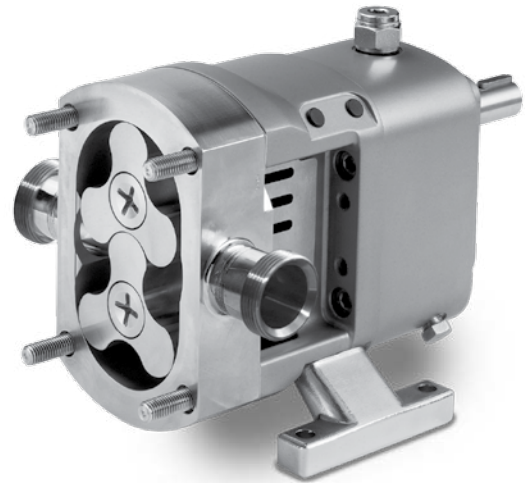

SERIES CP20 Pump

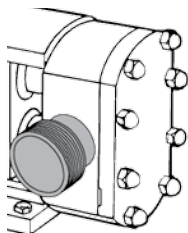

External NPT Ports

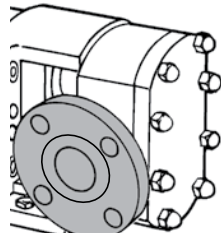

Flanged Ports

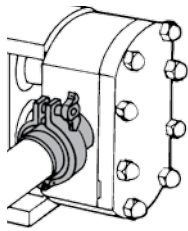

Quick-Clamp Ports

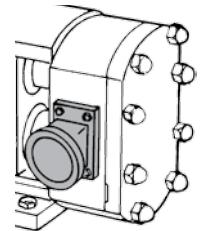

Rectangular or Enlarged Adapter Ports

PORTING OPTIONS

The Classic+ offers a variety of porting options to suit your specific application. Standard on the CP10 - CP30L are external NPT ports. Flanged ports, suitable for 150# stainless steel companion flanges or flanged fittings, are standard on the CP30L - CP50L series. Flanged ports are available on all sizes, Clamp ports are also available. For highly viscous liquids, enlarged rectangular ports are available for sizes CP10L - CP50L.

TRI-LOBE ROTORS

Multi-lobe (CP10) and traditional tri-lobe (CP20-CP50) rotors provide efficient, smooth pumping flow with low shear, maximized displacement and reduce slip.



The Viking Classic+ is designed for applications requiring a “traditional” tri-lobe rotary pump. With 316 stainless steel product-wetted parts and a low-shear pumping action, the Classic+ can handle a wide variety of industrial applications.

The Classic+ is a positive-displacement pump offering reversible flow, self-priming, continuous or intermittent, and dry-running abilities.

Front loading mechanical seals are available as single, single-quenched, double-flushed arrangements and single O-ring seals.

Precision helical gears maintain pump head clearances and timing thereby eliminating metal-to-metal contact. Shaft alignment is rigid and accurate because of a cast iron gearbox which serves as an oil reservoir for bearing and gear lubrication.

To meet the exact requirements of your specific application, the Classic+ provides jacketing, relief valve, and porting options.

Maximum displacement, smooth running flow, continuous gear and bearing lubrication, and rigid shaft alignment all combine for maximum efficiency and value in the Classic+ series of pumps.



ATEX Certification available.

① Values shown represent minimums or maximums. Some special construction or consideration may be required before a cataloged pump can be applied to an application involving maximum pressure or minimum or maximum temperature and/or viscosity and/or speed.
 ② Nominal capacities based on handling thin liquids at low pressures.

Section	285
Page	285.2
Issue	C

classic+
SERIES CP10, CP20, CP30, CP40, AND CP50

UNMOUNTED PUMPS

CONSTRUCTION — SERIES CP10, CP20, CP30, CP40, AND CP50

Standard	Model Numbers	Casing and Head	① Rotors	Bearing Housing Assembly	⑫ Gearbox	Gearbox Cover	⑩ Mechanical Seals (2 Required)	② Elastomers	Relief Valve	Mounting Feet
	CP10 CP20 CP30	316 Stainless Steel ASTM A 743, Grade CF8M	316 Stainless Steel ASTM A 743, Grade CF8M	Cast Iron	Cast Iron	NA	Carbon Graphite/ Stainless Steel	Viton®	③ None	304 Stainless Steel ASTM A 743, Grade CF8
CP40 CP50	NA	NA	NA	NA	Mild Steel	NA	NA	NA	Cast Iron	

SPECIFICATIONS — SERIES CP10, CP20, CP30, CP40, AND ICP50

Model Numbers Unmounted Pumps	Port Size	Theoretical Displacement per 100 Rev		⑥ Nominal Pump Rating			Maximum Hydrostatic Pressure		⑧ Maximum Recommended Discharge Pressure When Handling 100 SSU Liquid		Maximum Temperature (See Clearance Table Below)		Approximate Shipping Weight Less Valve (Less Power)	
	Inches	GAL	Liters	GPM	L/MIN	RPM	PSIG	⑦ BAR	PSIG	⑦ BAR	Degrees F.	Degrees C.	Pounds	KG
CP10S	④ 1	1.22	4.61	14	53	1150	300	20	175	12	300	150	29	13
CP10M	④ 1½	2.19	8.29	26	95				115	8			31	14
CP10L	④ 1½	2.93	10.71	34	128				70	5			33	15
CP20S	④ 1½	5.34	20.21	48	190	950	300	20	175	12	300	150	62	28
CP20L	④ 2	8.27	31.30	74	297				100	7			68	31
CP30S	④ 2	18.34	69.42	136	541	780	300	20	175	12	300	150	157	71
CP30L	⑤ 3	29.72	112.72	217	877				100	7			170	77
CP40S	⑤ 3	47.56	180.03	285	1079	640	300	20	175	12	300	150	331	150
CP40L	⑤ 4	66.05	250.02	395	1495				100	7			357	162
CP50S	⑤ 4	92.84	351.43	535	2249	640	300	20	175	12	350	180	555	252
CP50L	⑤ 6	138.71	525.07	650	2730				520	115			8	599

MECHANICAL SEALS

Mechanical Seals			
	Seal Style (2 Required)	Seal Faces	⑨ Elastomers
Standard	Single	Carbon / Stainless Steel	Viton®
Optional	Single mechanical seal or Single mechanical seal with quench/flush	Carbon / Stainless Steel Carbon/Silicon Carbide Silicon Carbide / Silicon Carbide	Viton® EPDM Buna N Perfluoroelastomer
	Double Mechanical Seals	Carbon/Silicon Carbide Carbon/Silicon Carbide Silicon Carbide / Silicon Carbide Carbon/Silicon Carbide	Viton® EPDM Buna N Perfluoroelastomer
	⑩ Single O-ring 10,000 SSU Maximum	---	Viton® EPDM Buna N Perfluoroelastomer

CLEARANCE TABLES

Clearances				
Model	Operating Temperature Limit °F (°C)			
	Class A	Class B	Class C	Class D
CP10, CP20, CP30, CP40	150 (70)	210 (100)	300 (150)	N/A
CP50	N/A	210 (100)	N/A	350 (180)

Clearance is set by temperature rather than viscosity on the Classic +. The operating temperature limit is determined by the rotor clearance. Standard clearance rated to 150°F (212°F on CP50). Additional clearances required for temperatures up to 350°F. Pump capacity will be reduced when operating with extra clearances especially on lower viscosities.

- ① Multi-Lobe (4 lobe) standard on CP10. Tri-Lobe standard on sizes CP20-CP50.
- ② Optional elastomers are EPDM, Buna N, and Perfluoroelastomer. FDA conforming elastomers available, contact factory.
- ③ Optional pressure relief valves available see page 285.7.
- ④ Pumps standard with external NPT ports. For optional ports refer to pages 285.6 to 285.7
- ⑤ Pump standard with 150# Raised Face Flange port. Ports are suitable for use with 150# ANSI stainless steel companion flanges or flanged fittings.
- ⑥ Nominal rating based on handling thin liquids.
- ⑦ 1 BAR = 0.1 MPa = 100 kPa = 10⁵ Pa.

- ⑧ For maximum recommended discharge pressures when handling other viscosities and/or speeds, see performance curves.
- ⑨ Not all elastomers available in specific seal styles or pump sizes.
- ⑩ Optional mechanical seals available to meet the requirements of industrial or sanitary applications.
- ⑪ Standard is Viton®. Maximum recommended speed for CP10 - CP30 is 640 RPM, for CP40 is 470 RPM. O-ring sealing not available on CP50.
- ⑫ Standard oil seal is Buna N, Viton® is an option.

Viton® is a registered trademark of DuPont Performance Elastomers

SPECIAL INFORMATION

UPDATED DESIGN

The Classic+ lobe pump has been redesigned allowing the casing and mounting foot to be rotated for horizontal and vertical mounting. With the exception of the casing gearbox, and mounting feet, all parts are interchangeable with the older Classic pump which allows the continued use of any existing inventory. The Classic+ is dimensionally interchangeable with the older Classic with the exception of the foot hole.



SLINGERS

A shaft slinger option is available which fits between the shaft seal and gear case. This will help to prevent product, which may leak by the mechanical seal, from entering past the lip seal into the gear box. The slingers can only be used with single mechanical seals.

STEAM CLEANING

Classic+ lobe pumps can be built with extra clearances to allow 300°F steam cleaning.* The pumps can be operated during cleaning cycle, but it is preferable to have the pump stopped. If pump is operated, wet steam is preferred to provide some liquid to the seal faces. Elastomers are of major concern, Viton® is not satisfactory with steam, EPR is satisfactory to 250°F. Some elastomers may have to be replaced after steam cleaning.

SURFACE FINISH

The standard machine finish is .8 μRA on the inside and outside of Classic+ lobe pumps.

ABRASIVE APPLICATIONS

Classic+ lobe pump can pass soft solids. The actual running clearance between the lobes and casing are very close, similar to the internal gear pump. Hard particles which are larger than the running clearance will cause abrasive wear and increase the internal clearances.

NOTE: Lobe pumps involving abrasive liquids should be reviewed by Applications.

SHAFT SEAL INFORMATION

There are four seal options for the Classic+ pumps:

- 1) Single mechanical seal
- 2) Single mechanical seal with quench/flush
- 3) Double mechanical seal with flush
- 4) Single O-ring seal.

SHAFT SEAL VISCOSITY LIMITS

Single Mechanical Seals:

Carbon vs. stainless steel	up to 25,000 SSU
Carbon vs. silicon carbide	up to 75,000 SSU
Silicon carbide vs. silicon carbide	up to 500,000 SSU
Double Mechanical Seals:	above 500,000 SSU
Single O-ring Seal	maximum 10,000 SSU

NOTE: Consult factory for viscosities above 500,000 SSU.

SINGLE SEAL WITH QUENCH/FLUSH

Single mechanical seal with quench requires a barrier fluid for lubricating the lip seal. Low pressure water is frequently used as the quench liquid to wash away product leakage and carry it to a drain. **NOTE: Quench pressure limit is 10 PSI.**

DOUBLE SEALS

A double seal is one in which the barrier fluid is pressurized above the pump discharge pressure and, therefore, the barrier fluid will be on the seal faces. It is recommended that barrier liquid be circulated between the inboard and outboard seal faces at a flow rate of 3/4 GPM and at a pressure 15 PSI above discharge pressure.

MECHANICAL SEAL QUENCH/FLUSH FLUID

The same flush connections are used for the single seal with quench and the double seals. Holes are standard in the seal gland for single seals with quench and double seals. **NOTE: The pipe connections are BSP (British Standard Pipe).**

FLUSH REQUIRED FOR RUN DRY OPERATION

The lobe pumps can operate dry but a seal flush is required, use a single seal with quench or double seals. Pumps with single seals (without quench) are not to be operated dry.

*Contact factory for steam cleaning recommendations.

Section	285
Page	285.4
Issue	C

classic+
SERIES CP10, CP20, CP30, CP40, AND CP50

DRIVE UNITS

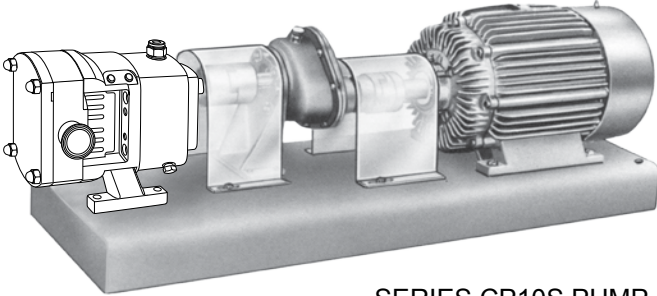

SERIES CP10S PUMP
with "R" Drive

The Classic+ can be mounted either as a Direct Drive ("D" mounting), or with a reducer ("R" mounting).

Direct drive units are specifically designed for compactness and quiet operation. The pump mounted on one end of a formed steel base and connected to a motor by means of a flexible coupling with a guard. The "CP10" pumps can be directly connected to 1150 RPM motors or gearhead motors. "D" Drive units can be single speed or inverter drive for reliable variable speed capabilities.

Viking helical gear reducers that have been specifically developed for efficient operation. These rugged, compact, exceptionally quiet gear reducers come in three sizes that are all bracket mounted utilizing flexible couplings for both input and output shafts.

With the Viking "A" size reducer four gear ratios (2.24, 2.76, 3.43, and 4.17 to 1) and 1150 or 1750 RPM motors, models in the CP10 and CP20 can cover capacities ranging to 60 GPM.

The medium size "B" helical gear reducer is available with eight gear ratios from 1.87 to 1 to 7.65 to 1. This size is normally used with pump sizes "CP20", and "CP30." When driven by the 1150 or 1750 RPM motors these pumps can be used for capacities to 217 GPM.

The large "C" size reducer is available with seven gear ratios from 2.21 to 1 to 7.95 to 1 and normally used with models "CP30," "CP40", and "CP50" size pumps. When driven by 1150 or 1750 RPM motors these pumps cover a capacity range to 650 GPM.

Dimensions for Drive Units – Contact the factory

Performance Data for Drive Units – See Pages 285.11 through 285.24.

SPECIFICATIONS — "D" DIRECT DRIVE UNITS

Model Numbers Unmounted Pumps	Port Size	Theoretical Displacement Per 100 Rev		① Nominal Pump Rating			Maximum Hydrostatic pressure		② Maximum Recommended Discharge Pressure When Handling 100 SSU Liquid		③ Maximum Temperature		Approximate Shipping Weight With Valve (Less Power)	
		Inches	GAL	Liters	GPM	L/MIN	RPM	PSIG	⑤ BAR	PSIG	⑤ BAR	Degrees F.	Degrees C.	Pounds
CP10S	③ 1	1.22	4.61	14	53	1150	300	20	175	12	300	150	79	36
CP10M	③ 1½	2.19	8.29	26	95	1150	300	20	115	8	300	150	81	37
CP10L	③ 1½	2.93	10.71	34	128	1150	300	20	70	5	300	150	83	38

SPECIFICATIONS — "R" REDUCER DRIVE UNITS

Model Numbers Unmounted Pumps	Port Size	Theoretical Displacement Per 100 Rev		① Nominal Pump Rating			Maximum Hydrostatic Pressure		② Maximum Recommended Discharge Pressure When Handling 100 SSU Liquid		③ Maximum Temperature		Approximate Shipping Weight With Valve (Less Power) Pounds/Kilograms					
		Inches	GAL	Liters	GPM	L/MIN	RPM	PSIG	⑤ BAR	PSIG	⑤ BAR	Degrees F.	Degrees C.	"A"	"B"	"C"		
CP10S	③ 1	1.22	4.61	14	53	1150	300	20	175	12	300	150	130	59	--	--	--	--
CP10M	③ 1½	2.19	8.29	26	95				115	8			132	60	--	--	--	--
CP10L	③ 1½	2.93	10.71	34	128				70	5			134	61	--	--	--	--
CP20S	③ 1½	5.34	20.21	48	190	950	300	20	175	12	300	150	215	98	240	109	--	--
CP20L	③ 2	8.27	31.30	74	297				100	7			221	100	246	112	--	--
CP30S	③ 2	18.34	69.42	136	541	780	300	20	175	12	300	150	--	--	340	154	545	247
CP30L	④ 3	29.72	112.72	217	877				100	7			--	--	353	160	558	253
CP40S	④ 3	47.56	180.03	285	1079	640	300	20	175	12	300	150	--	--	--	--	720	326
CP40L	④ 4	66.05	250.02	395	1495				100	7			--	--	--	--	746	338
CP50S	④ 4	92.84	351.43	535	2249	640	300	20	175	12	350	175	--	--	--	--	1125	510
CP50L	④ 6	138.71	525.07	650	2730				115	8			--	--	--	--	1169	530

① Nominal rating based on handling thin liquids.

② For maximum recommended discharge pressures when handling other viscosities and/or speeds, see performance curves.

③ Pumps standard with external NPT ports. For optional ports refer to pages 285.6.

④ Pump standard with 150# Raised Face Flange port. Ports are suitable for use with 150# ANSI stainless steel companion flanges or flanged fittings.

⑤ 1 BAR = 0.1 MPa = 100 kPa = 10⁵ Pa.

⑥ Standard clearance rated to 150°F (210°F on CP50). Additional clearances required for temperatures up to 350°F. Pump capacity will be reduced when operating with reduced clearances especially on lower viscosities. Refer to table on page 2.

Section	285
Page	285.5
Issue	C

DIMENSIONS—SERIES CP10, CP20, CP30, CP40, AND CP50 UNMOUNTED PUMPS

Dimensions given are for guidance only and should not be used for installation purposes. Certified dimensions will be supplied on request. Dimensions are calculated based on millimeters, inch measurements are provided for reference.

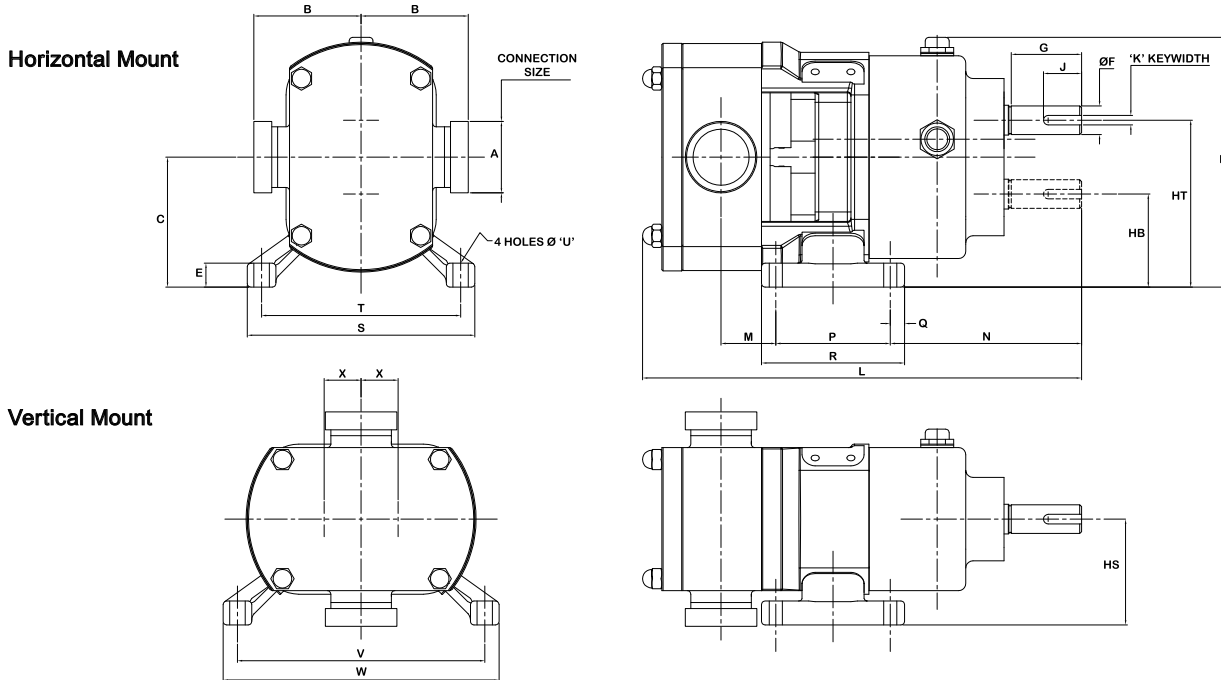

MODEL	① MOUNTING	A	⑤ B	C	D	E	④ F mm	G	HB	HS	HT	J	④ K mm	L	M	N	P	Q	R	S	T	U	V	W	X		
CP10S	H V	② 1	in 3.5	2.91	6.18	0.39	18	1.10	1.89	2.48	3.94	0.98	6	9.80	1.87	4.58	1.77	0.39	2.56	5.75	4.96	0.33	6.40	7.20	1.02		
		mm 89	74	157	10	28		48	63	100	25	249		47.5	116.40	45	10	65	146	126	8.50	162.5	183	26			
CP10M	H V	② 1.5	in 4.37	2.91	6.18	0.39	18	1.10	1.89	2.48	3.94	0.98	6	10.39	2.15	4.58	1.77	0.39	2.56	5.75	4.96	0.33	6.40	7.20	1.02		
		mm 111	74	157	10	28		48	63	100	25	264		54.5	116.40	45	10	65	146	126	8.50	162.5	183	26			
CP10L	H V	② 1.5	in 4.37	2.91	6.18	0.39	18	1.10	1.89	2.48	3.94	0.98	6	10.87	2.58	4.58	1.77	0.39	2.56	5.75	4.96	0.33	6.40	7.20	1.02		
		mm 111	74	157	10	28		48	63	100	25	276		65.5	116.40	45	10	65	146	126	8.50	162.5	183	26			
CP20S	H V	② 1.5	in 4.72	4.29	8.62	0.79	24	2.32	3.07	3.49	5.51	1.26	8	13.74	1.38	6.32	3.78	0.47	4.72	7.68	6.57	0.43	8.17	9.27	1.22		
		mm 120	109	219	20	59		78	88.75	140	32	349		35	160.50	96	12	120	195	167	11	207.5	235.5	31			
CP20L	H V	② 2	in 4.72	4.29	8.62	0.79	24	2.32	3.07	3.49	5.51	1.26	8	14.53	1.81	6.32	3.78	0.47	4.72	7.68	6.57	0.43	8.17	9.27	1.22		
		mm 120	109	219	20	59		78	88.75	140	32	369		46	160.50	96	12	120	195	167	11	207.5	235.5	31			
CP30S	H V	② 2	in 5.75	5.26	10.71	0.98	38	2.74	3.43	4.38	7.09	1.57	10	17.44	2.39	7.74	4.53	0.59	5.71	10.16	8.98	0.51	10.72	11.90	1.83		
		mm 146	133.5	272	25	69.5		87	111.3	180	40	443		60.6	196.50	115	15	145	258	228	13	272.3	302.3	46.5			
CP30L	H V	③ 3	in 5.75	5.26	10.71	0.98	38	2.74	3.43	4.38	7.09	1.57	10	18.82	3.17	7.74	4.53	0.59	5.71	10.16	8.98	0.51	10.72	11.90	1.83		
		mm 146	133.5	272	25	69.5		87	111.3	180	40	478		80.6	196.50	115	15	145	258	228	13	272.3	302.3	46.5			
CP40S	H V	③ 3	in 7.13	6.97	13.50	0.91	48	4.33	4.49	6.89	9.45	3.54	14	25.47	6.42	10.35	4.72	0.89	6.50	8.66	7.24	---	---	0.71	---	---	2.48
		mm 181	177	343	23	110		114	175	240	90	647		163	262.80	120	22.5	165	220	184	18	---	---	---	18	---	---
CP40L	H V	③ 4	in 7.13	6.97	13.50	0.91	48	4.33	4.49	6.89	9.45	3.54	14	26.73	7.14	10.35	4.72	0.89	6.50	8.66	7.24	---	---	0.71	---	---	2.48
		mm 181	177	343	23	110		114	175	240	90	679		181.3	262.80	120	22.5	165	220	184	18	---	---	---	18	---	---
CP50S	H V	③ 4	in 8.27	8.46	16.61	1.18	60	4.09	5.32	8.07	11.61	2.32	18	29.72	8.35	11.22	5.91	0.98	7.87	10.24	8.66	---	---	0.79	---	---	3.15
		mm 210	215	422	30	104		135	205	295	59	755		212	285	150	25	200	260	220	20	---	---	---	20	---	---
CP50L	H V	③ 6	in 7.17	8.46	16.61	1.18	60	4.09	5.32	8.07	11.61	2.32	18	32.09	9.45	11.22	5.91	0.98	7.87	10.24	8.66	---	---	0.79	---	---	3.15
		mm 182	215	422	30	104		135	205	295	59	815		240	285	150	25	200	260	220	20	---	---	---	20	---	---

① H=Horizontal Mounting & V = Vertical Mounting.
 ② Pumps standard with external NPT ports.
 ③ Ports are suitable for use with 150# ANSI stainless steel companion flanges or flanged fittings.
 ④ Metric shaft coupling and key required.
 ⑤ "For "B" dimension for other than standard port options see page 285.6.

NOTE: For optional rectangular ports see pages 285.6 and 285.7.
NOTE: For optional jacketed head and casing see pages 285.8.
NOTE: For optional relief valves see page 285.9.

Section	285
Page	285.6
Issue	C

classic+
SERIES CP10, CP20, CP30, CP40, AND CP50

“B” DIMENSIONS FOR VARIOUS PORT OPTIONS

Dimensions given are for guidance only and should not be used for installation purposes. Certified dimensions will be supplied on request. Dimensions are calculated based on millimeters. Inch measurements are provided for reference.

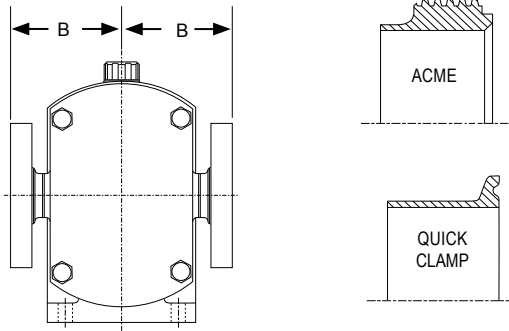

MODEL	“B” Dimensions Inch (mm)				
	Port Size	Acme	Quick Clamp	① 150# Flange	③ 300# Flange
CP10S	① 1”	3.50 (89)	3.50 (89)	4.05 (103)	4.05 (103)
CP10M	① 1-1/2”	3.50 (89)	3.50 (89)	4.05 (103)	4.05 (103)
CP10L	① 1-1/2”	3.50 (89)	3.50 (89)	4.05 (103)	4.05 (103)
CP20S	① 1-1/2”	3.86 (98)	3.86 (98)	4.41 (112)	4.41 (112)
CP20L	① 2”	3.86 (98)	3.86 (98)	4.41 (112)	4.72 (120)
CP30S	① 2”	4.88 (124)	4.88 (124)	5.43 (138)	5.75 (146)
CP30L	② 3”	4.88 (124)	4.88 (124)	5.75 (138)	5.95 (151)
CP40S	② 3”	6.26 (159)	6.26 (159)	7.13 (173)	7.32 (186)
CP40L	② 4”	6.42 (163)	6.42 (163)	7.13 (173)	7.32 (186)
CP50S	② 4”	7.40 (188)	7.40 (188)	8.27 (202)	8.46 (215)
CP50L	② 6”	NA	NA	7.16 (182)	NA

- ① Pumps standard with external NPT ports.
- ② Pump standard with 150# Raised Face Flange port. Ports are suitable for use with 150# ANSI stainless steel companion flanges or flanged fittings.
- ③ Raised Face Flanges.

DIMENSIONS FOR OPTIONAL ENLARGED RECTANGULAR PORTS

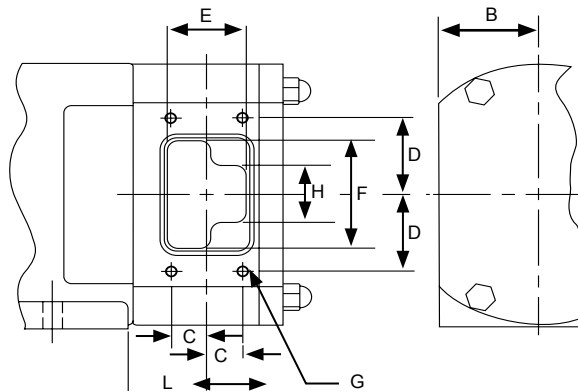

MODEL	B	C	D	E	F	H	L	G			Inlet Area Square Inch	Equivalent Bore Diameter	O-Ring Dash No.
								No. Bolts	Metric Threads	Depth			
CP10S	NA	NA	NA	NA	NA	NA	NA	NA	NA	NA	NA	NA	NA
CP10M	NA	NA	NA	NA	NA	NA	NA	NA	NA	NA	NA	NA	NA
CP10L	2.01	0.71	1.68	1.57	2.36	1.26	2.60	4	M6	0.39	2.87	1.91	-037
CP20S	2.36	0.49	2.07	1.10	3.15	NA	1.10	4	M8	0.39	2.93	1.93	-146
CP20L	2.36	0.89	2.07	1.89	3.15	NA	1.50	4	M8	0.39	5.41	2.62	-641/ -151
CP30S	3.35	0.79	2.86	1.69	4.49	NA	1.54	4	M10	0.47	7.34	3.06	-155
CP30L	3.35	1.38	2.86	3.07	4.49	NA	2.24	4	M10	0.47	12.82	4.15	-158
CP40S	4.76	1.22	3.74	2.76	5.98	2.76	5.51	4	M10	0.59	13.82	4.19	-254
CP40L	4.76	1.85	3.74	4.02	5.98	2.76	6.14	4	M10	0.59	21.36	5.21	-259
CP50S	5.91	1.57	4.92	3.39	7.87	NA	6.81	4	M10	0.59	23.84	5.51	-263
CP50L	NA	NA	NA	NA	NA	NA	NA	NA	NA	NA	NA	NA	NA

All dimensions are in inches (except for thread sizes).
For all other pump dimensions refer to Page 285.5.

**OPTIONAL ENLARGED RECTANGULAR PORTS
- WITH ADAPTOR**

Dimensions given are for guidance only and should not be used for installation purposes. Certified dimensions will be supplied on request. Dimensions are calculated based on millimeters, inch measurements are provided for reference.

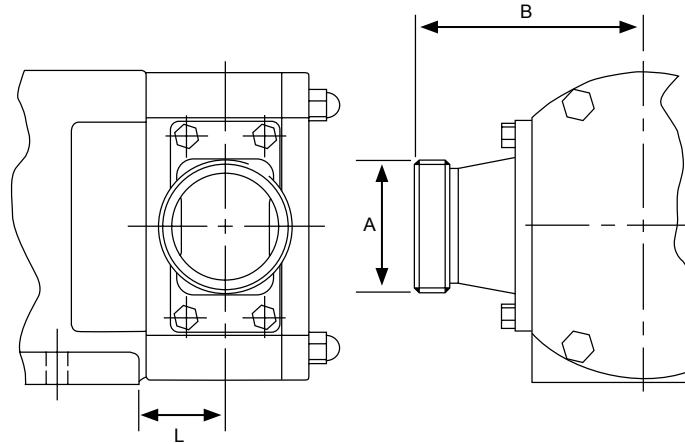

MODEL	A	"B" DIMENSION				L
		NPT	ACME	CLAMP	150# FLANGE ①	
CP10S	NA	NA	NA	NA	NA	NA
CP10M	NA	NA	NA	NA	NA	NA
CP10L	2"	5.55	4.69	4.69	5.24	2.60
CP20S	2"	6.30	5.43	5.43	5.98	1.10
CP20L	3"	6.69	5.43	5.43	6.30	1.50
CP30S	3"	8.46	7.20	7.20	8.07	1.54
CP30L	4"	9.06	7.36	7.36	8.07	2.24
CP40S	4"	10.47	8.78	8.78	9.49	5.51
CP40L	6"	10.47	8.94	8.94	9.49	6.14
CP50S	6"	11.61	10.08	10.08	10.63	6.81
CP50L	NA	NA	NA	NA	NA	NA

For all other pump dimensions refer to Page 285.5.

Section	285
Page	285.8
Issue	C

classic+
SERIES CP10, CP20, CP30, CP40, AND CP50

DIMENSIONS FOR OPTIONAL JACKETED HEAD

Dimensions given are for guidance only and should not be used for installation purposes. Certified dimensions will be supplied on request. Dimensions are calculated based on millimeters, inch measurements are provided for reference.

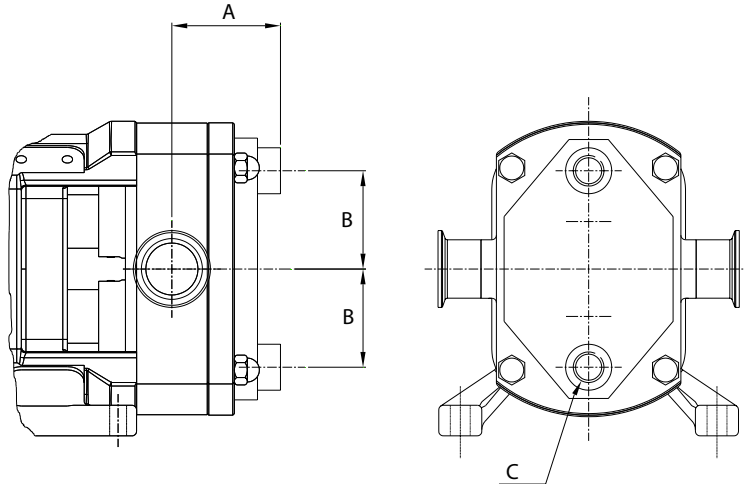

MODEL	INCHES		
	A ①	B	C ②
CP10S CP10M CP10L	2.05 2.40 2.40	1.97 1.97 1.97	1/4 1/4 1/4
CP20S CP20L	2.80 3.19	2.52 2.52	1/2 1/2
CP30S CP30L	3.19 3.78	3.64 3.64	1/2 1/2
CP40S CP40L	4.25 4.84	5.12 5.12	1/2 1/2
CP50S CP50L	4.53 5.43	6.89 6.89	1/2 1/2

DIMENSIONS FOR OPTIONAL JACKETED CASING

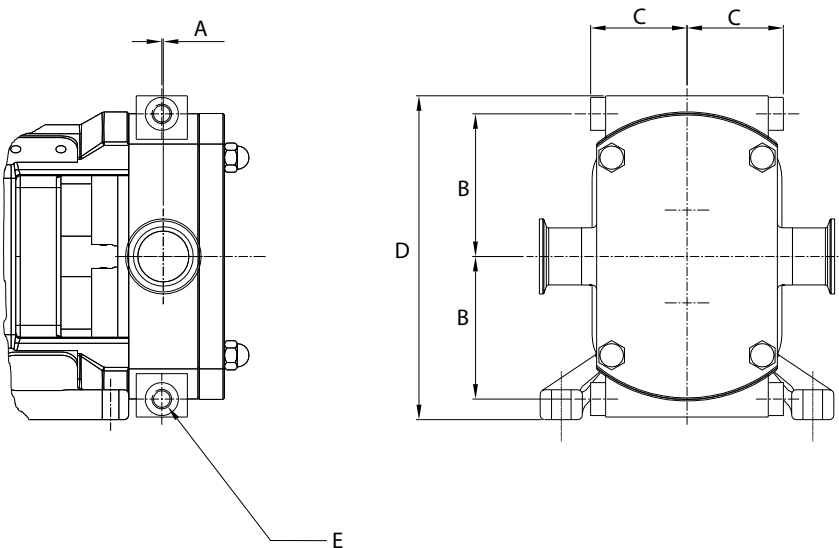

MODEL	INCHES				
	A ①	B	C	D	E ②
CP10S CP10/M CP10L	0.12 0.08 0.30	2.76 2.76 2.76	2.20 2.20 2.20	6.14 6.14 6.14	1/4 1/4 1/4
CP20S CP20L	0.00 0.04	3.15 3.15	2.52 2.52	8.50 8.50	1/4 1/4
CP30S CP30L	0.04 0.14	4.65 4.65	3.66 3.66	11.02 11.02	1/2 1/2
CP40S CP40L	0.10 0.14	6.14 6.14	4.92 4.92	13.86 13.86	1/2 1/2
CP50S CP50L	0.31 0.39	7.52 7.52	6.10 6.10	16.93 16.93	1/2 1/2

- ① Based on Standard Port Configurations.
- ② (BSP) British Standard Pipe internal threads.

Dimensions in inches.
 For all other pump dimensions, refer to Page 5.
 Maximum temperature for steam or heat transfer liquid: 300°F (150°C).
 Maximum pressure: 50 PSI (3.5 BAR).
 Relief valve cannot be used in combination with jacketed head.

DIMENSIONS FOR OPTIONAL INTEGRAL PRESSURE RELIEF VALVES

Dimensions given are for guidance only and should not be used for installation purposes. Certified dimensions will be supplied on request. Dimensions are calculated based on millimeters, inch measurements are provided for reference.

RELIEF VALVE OPTIONS

1. Classic+ pumps are positive displacement pumps and must be provided with some sort of over pressure protection. This may be an optional relief valve mounted directly on the pump, an in-line pressure relief valve, a torque limiting device or a rupture disk.
2. Relief valves are not standard on Classic+ pumps but a spring loaded relief valve is available as an option. This optional pump mounted relief valve will operate in either pumping direction.

Spring Loaded – This is a conventional type relief valve where pressure is relieved from the discharge side of the pump back to the suction side. Relief valve setting may be adjusted.

3. Note that Classic+ pumps may operate in either direction. When using a line mounted pressure relief valve, if pump rotation is reversed during operation, over - pressure protection must be provided on *both* sides of pump.
4. Pressure relief valves should not be used to control pump flow or regulate discharge pressure.

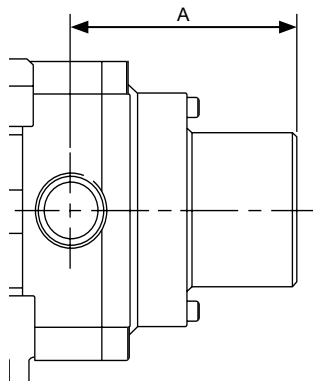

Spring Loaded Relief Valve Option

MODEL	"A" DIMENSIONS ①
CP10S CP10M CP10L	5.67 6.02 6.02
CP20S CP20L	6.73 7.13
CP30S CP30L	8.98 9.56
CP40S CP40L	NA NA
CP50S CP50L	NA NA

① Based on Standard Port Configuration Dimensions in inches.

For all other pump dimensions refer to Page 285.5.

Integral relief valve cannot be used in combination with jacketed front cover.

Section	285
Page	285.10
Issue	C

 classic+
SERIES CP10, CP20, CP30, CP40, AND CP50

INTENTIONALLY BLANK