

## VIKING SG SERIES SEALLESS MAG DRIVE PUMPS

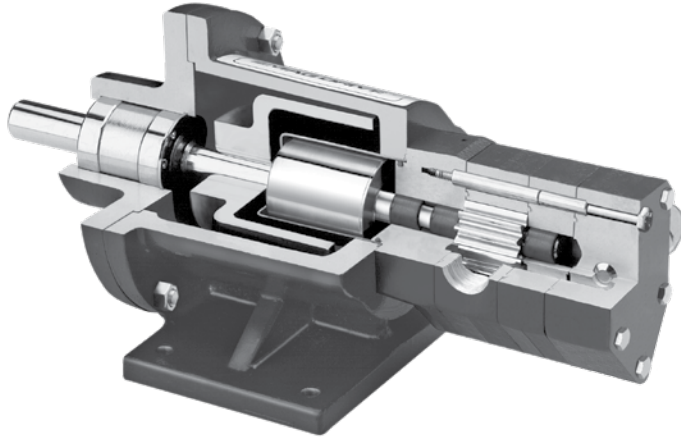

### OPERATING RANGE:

SG8 Pumps (Cast Iron Mag Drive) and SGN8 (Ductile Iron Mag Drive)		
Displacements	No.	23 SG8 and 17 SGN8
Flow Range	GPM	0.06 to 190 (SG8) and 0.7 to 32 (SGN8)
	M <sup>3</sup> /Hr	0.013 to 43 (SG8) and 0.16 to 7.2 (SGN8)
Pressure Range	PSI	to 500 Continuous
	Bar	to 34 Continuous
Temperature Range	°F	-40° to 500°
	°C	-40° to 260°
Viscosity Range	SSU	28 to 250,000
	cSt	1 to 55,000

Where shaft seal leakage is not allowable, for liquids that are hard to seal, or where seal maintenance is difficult, Viking Mag Drive® sealless SG pumps are the solution. In this type of pump, a canister hermetically seals the liquid within the pump. Inner magnets are connected to the pump drive shaft inside the canister, and an outer magnet assembly rotates outside of the canister, driven by a motor or other drive, so that magnetic forces pass through the canister to the inner magnets and cause the drive shaft to rotate. This eliminates traditional dynamic shaft seals, and problems associated with them (wear, leakage, air infiltration).

A hollow drive shaft allows some liquid to flow by means of pressure differential from the high pressure side of the pump through the shaft, into the canister and back to the low pressure side of the pump. This provides magnet cooling and prevents product stagnation.

### TYPICAL APPLICATIONS:

- Fuels and Additives
- Polyurethane Meter / Mix
- Adhesive & Sealant Dispensing
- Pipeline Sampling
- Chemical Metering
- Heat Transfer Oils

Section	341.3
Page	341.3.2
Issue	C

**SERIES SG-804, -805, -807, -810, -814 (Cast Iron)  
SGN-805, -807 (Ductile Iron)**



## VIKING SG SERIES SEALLESS MAG DRIVE PUMPS

### MATERIALS OF CONSTRUCTION - ALL SERIES

Component	Standard - SG-804, -805, -807	Standard - SGN-805, -807	Standard - SG-810, -814	Options
Casing, Bracket, Head, Separation Plate	Cast Iron ASTM A823	Ductile Iron ASTM A536	Cast Iron ASTM A823	Surface Hardening (Vitek)
Relief Valve Body	Cast Iron ASTM A823	Ductile Iron ASTM A536	Cast Iron ASTM A48	— — —
Relief Valve Poppet	Hardened Steel	Hardened Steel	Ductile Iron ASTM A536	— — —
Relief Valve Spring	Steel ASTM A229	Steel ASTM A229	Chrome Silicon Spring Steel ASTM A401	— — —
Gears	Hardened Steel	Hardened Steel	Hardened Steel	PPS (composite) SG-807 only
Shafts	Case-Hardened Steel ASTM A322	Case-Hardened Steel ASTM A322	Case-Hardened Steel ASTM A322	Nitralloy
Anti-Friction Needle Bearings	— — —	— — —	— — —	Bearing Steel
Sleeve Bearings	Carbon Graphite	Carbon Graphite	Carbon Graphite	Silicon Carbide
O-Rings	Buna-N	Buna-N	Buna-N	Neoprene, Viton®, PTFE, Kalrez®
Canister	316L Stainless Steel	316L Stainless Steel	316L Stainless Steel	Alloy C
Magnetic Coupling Bracket (not wetted)	Cast Iron ASTM A823	Cast Iron ASTM A823	Cast Iron ASTM A823	Aluminum SG-804,-805,-807 only
Magnets (outer magnets nickel plated, inner magnets sealed in SS canister)	① Neodymium Iron Boron	① Neodymium Iron Boron	① Neodymium Iron Boron	② Samarium Cobalt

① Maximum temperature 225°F / 107°C.  
② Maximum temperature 500°F / 260°C.

### MODEL NUMBER KEY

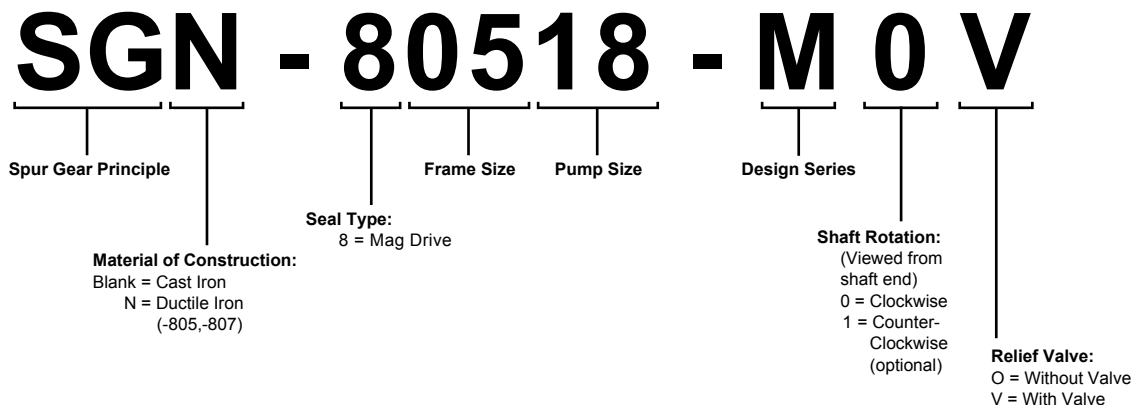

**NOTE:** Direction of rotation: clockwise is standard, counter-clockwise is optional.  
Bi-rotational is not available as Mag Drive.

**NOTE:** Mag Drive pumps are connected to a magnetic coupling, which is specified separately.  
Coupling options are MD-A and MD-B (SG-804,-805,-807), MD2-B (SG-810) or MD2-C (SG-814).  
Specify NEMA or IEC face mount for close-coupled or bearing carrier for long-coupled.  
See page 341.3.4 to determine the correct coupling.

*Viton® and Kalrez® are registered trademarks of DuPont Performance Elastomers*



SERIES SG-804, -805, -807, -810, -814 (Cast Iron)  
SGN-805, -807 (Ductile Iron)

Section	341.3
Page	341.3.3
Issue	C

## VIKING SG SERIES SEALLESS MAG DRIVE PUMPS

### SPECIFICATIONS SERIES SG-804, SG-805, SG-807, SG-810, SG-814 (CAST IRON) - SGN-805, SGN-807 (DUCTILE IRON)

Model Numbers		Port Size	Nominal Pump Rating				Maximum Continuous Pressure		② Magnetic Coupling Availability			① Maximum Hydrostatic Pressure		Approximate Shipping Weight Pump With Valve (Less Power)		Approximate Coupling Only Shipping Weight (ready to accept but less power)	
			60 Hz Motor Speed		50 Hz Motor Speed				Torque			PSIG	Bar	Lbs	KG	Lbs	KG
Cast Iron	Ductile Iron	Inches	GPM	RPM	M <sup>3</sup> /Hr	RPM	PSI	Bar	Series	Ft-Lbs	Nm	PSIG	Bar	Lbs	KG	Lbs	KG
SG-80417		3/8 ③	0.06	1750	0.011	1450	500	34	MD-A	4	5.4	1000	69	6	2.7	31	14
SG-80418		3/8 ③	0.14	1750	0.026	1450	500	34									
SG-80425		3/8 ③	0.18	1750	0.034	1450	500	34									
SG-80435		3/8 ③	0.27	1750	0.051	1450	500	34									
SG-80450		3/8 ③	0.36	1750	0.068	1450	500	34									
SG-80470		3/8 ③	0.50	1750	0.094	1450	500	34									
SG-80518	SGN-80518	1/2 ③	0.70	1750	0.13	1450	500	34	MD-A	4	5.4	1000	69	6	2.7	31	14
SG-80525	SGN-80525	1/2 ③	1	1750	0.19	1450	500	34									
SG-80535	SGN-80535	1/2 ③	1.4	1750	0.26	1450	500	34									
SG-80550	SGN-80550	1/2 ③	2	1750	0.38	1450	500	34									
SG-80570	SGN-80570	1/2 ③	2.8	1750	0.53	1450	500	34									
SG-80510	SGN-80510	1/2 ③	4	1750	0.75	1450	500	34									
SG-80514	SGN-80514	3/4 ③	5.6	1750	1.05	1450	500	34									
SG-80519	SGN-80519	3/4 ③	7.6	1750	1.43	1450	200	14									
SG-80528	SGN-80528	3/4 ③	11.2	1750	2.11	1450	100	7									
SG-80741	SGN-80741	1 ③	4	1750	0.75	1450	500	34									
SG 80758	SGN 80758	1 ③	5.6	1750	1.05	1450	500	34									
SG-80782	SGN-80782	1 ③	8	1750	1.51	1450	500	34	MD-A	4	5.4	1000	69	15	6.8	31	14
SG-80711	SGN-80711	1 ③	11.2	1750	2.11	1450	500	34									
SG-80716	SGN-80716	1 ③	16	1750	3.01	1450	500	34									
SG-80722	SGN-80722	1 1/2 x 1 1/4 ③	22	1750	4.14	1450	500	34	MD-B	15	20.3	400	28	17	7.7	71	32
SG-80732	SGN-80732	1 1/2 x 1 1/4 ③	32	1750	6.02	1450	500	34									
SG-81009		1 ④	16	1750	3.01	1450	500	34	MD2-B	14	19	700	48	18	8.2		
SG-81013		1 1/2 ④	25	1750	4.70	1450	500	34									
SG-81026		2 ④	50	1750	9.41	1450	500	34									
SG-81420		2 ④	70	1750	13.17	1450	500	34	MD2-C	40	54	350	24	19	8.6		
SG-81436		3 ④	125	1750	23.52	1450	290	20									
SG-81456		4 ④	190	1750	35.75	1450	190	13									

NOTE: Maximum temperature (standard construction) 225°F, 107°C. Higher temperatures can be handled with Samarium Cobalt magnets and optional O-ring elastomers. See page 341.3.4 for torque and temperature limits.

① Optional high pressure canisters available. Consult factory.

② See page 341.3.4 for "Selecting the correct Mag Drive coupling."

③ NPT standard. Consult factory for other port size or type options such as BSP, SAE O-Ring or other.

④ SAE J518 Code 61 flange with metric threaded fastener holes standard. Consult factory for other port sizes or type options such as NPT, BSP, SAE O-Ring or other.

Metric conversions are based on US measurements.

Section	341.3
Page	341.3.4
Issue	C

**SERIES SG-804, -805, -807, -810, -814 (Cast Iron)**  
**SGN-805, -807 (Ductile Iron)**



## VIKING SG SERIES SEALLESS MAG DRIVE PUMPS

### SELECTING THE CORRECT VIKING MAG DRIVE® COUPLING

With any mag drive pump, the magnetic forces between the inner and outer magnets must meet or exceed the torque generated by the drive at the application's peak flow, speed and pressure, or the magnets will decouple, which can cause permanent loss of magnetic attraction.

Instead of offering mag drive pumps with just one torque rating, Viking allows you to select between several magnetic couplings with different torque ratings. This ensures enough torque for the application, but keeps costs down by using only as much torque as is needed.

Viking also offers two magnet materials in each of the coupling sizes. The standard Neodymium magnets are lowest cost, but are limited in temperature to 225°F (107° C). The optional Samarium Cobalt magnets range up to 500°F (260° C). Specify magnet material when ordering.

#### Selecting the Right Coupling

1. Find pump HP and speed from performance curves using the Pump Selector program on [www.vikingpump.com](http://www.vikingpump.com)
2. Calculate application torque (T), using this formula:  
 $T \text{ (FT LB)} = \text{HP/SPEED} \times 5252$
3. Select temperature correction factor (TCF) from Table 1 or Table 2.
4. Divide the calculated application torque (T) by the temperature correction factor (TCF) to get the Adjusted Application Torque.
5. Select the coupling with a torque rating (from Table 3) equal to or greater than the Adjusted Application Torque (AAT). Viking couplings have a built-in service factor, so if you have calculated the AAT correctly, you can be comfortable with a coupling that is equal to your calculated torque.

Temperature Correction Factors for Standard Neodymium Magnets							
Application Temp. (°F)	68	100	125	150	175	200	225
Application Temp. (°C)	20	38	52	66	79	93	107
TC Factor	1.0	0.94	0.88	0.82	0.76	0.70	0.64

**TABLE 1**

Temperature Correction Factors for Optional Samarium Cobalt Magnets					
Application Temp. (°F)	175	200	300	400	500
Application Temp. (°C)	79	93	149	204	260
TC Factor	0.74	0.73	0.69	0.63	0.59

**TABLE 2**

Magnetic Coupling Torque Capacity		
Coupling Size 1	Torque (FT-LBS)	Nm
MD-A4	4	5.4
MD-A9	9	12.2
MD-B15	15	20.3
MD-B40	40	54.2
MD2-B14	14	19.0
MD2-B32	32	43.4
MD2-B50	50	67.8
MD2-C40	40	54.2
MD2-C90	90	122.0
MD2-C135	135	183.0
MD2-C180	180	244.0

**TABLE 3**

#### Example 1:

1. An application calls for pumping 1 GPM of 100 SSU (22 cSt) liquid at 400 PSI (27 Bar), at 100°F (38°C), with a 1750 RPM motor. From the Pump Selector program, an SG80525 is selected, providing 0.95 GPM (3.6 lpm) at 1750 RPM, with 0.35 BHP (0.26 kW).
2. Calculate torque.  $T = 0.35 / 1750 \times 5252 = 1.05$
3. From Table 1, the TCF is 0.94.
4.  $AAT = 1.05 / 0.94 = 1.12 \text{ FT-LB}$ .
5. Select MD-A4 coupling in standard Neodymium magnet material (4 FT-LB rating >1.12 FT-LB Adjusted Application Torque)



SERIES SG-804, -805, -807, -810, -814 (Cast Iron)  
SGN-805, -807 (Ductile Iron)

Section	341.3
Page	341.3.5
Issue	C

## VIKING SG SERIES SEALLESS MAG DRIVE PUMPS

### DRIVE OPTIONS

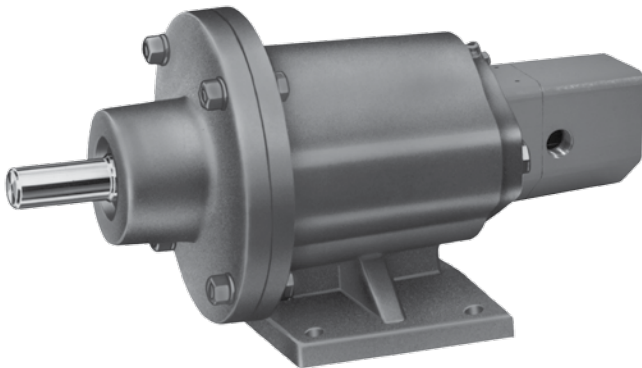

#### FOOT-BRACKET MOUNTED PUMPS (“B” DRIVE)

Series SG-8 pumps are available with a bearing carrier mounted to the magnetic coupling to provide an external drive shaft for long-coupling to a reducer, gear motor or other drive. The 3.5” shaft height on MD-A couplings matches the shaft height on Viking “A” series reducers, as well as NEMA 56, 143 and 145 T motors. The 6.25” shaft height on MD-B couplings matches shaft height on 254/256 T motors. The MD2-B coupling for SG-810 has 5.5” shaft height matching Viking “B” reducers.

*Dimensions for Foot-Bracket Mounted Pumps (“B” Drive)—  
See Pages 341.3.6 - 341.3.9.*

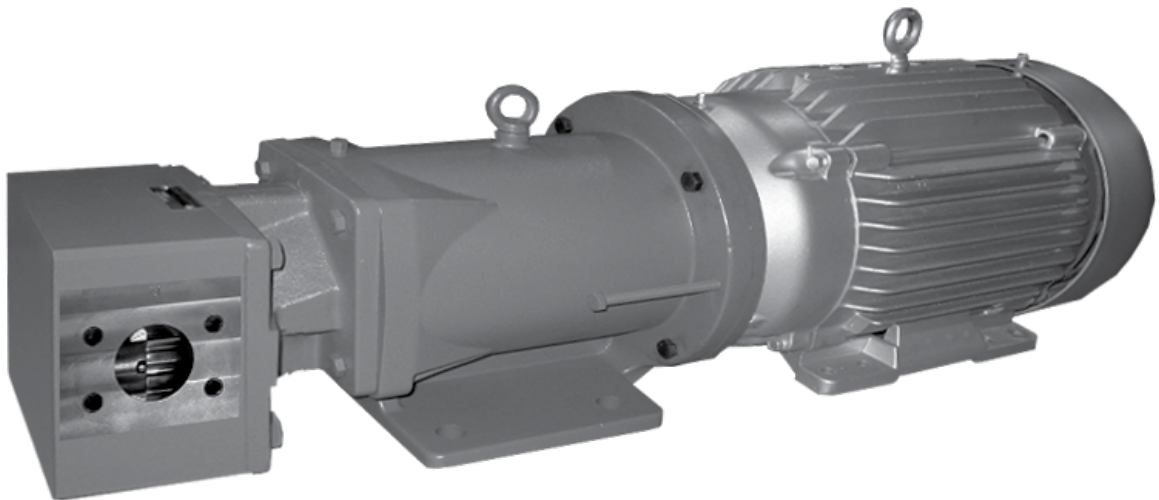

#### MOTOR MOUNTED UNITS (“M” DRIVE)

Series SG-804, -805 & -807 pumps may be close coupled to NEMA-C faced motors and SG-810 & -814 to both NEMA-C and IEC B5 flanged motors to provide an easily-assembled, compact pumping unit. This mounting arrangement eliminates the need for on-site coupling alignment that is normally required for a base-mounted unit.

*Dimensions for Motor Mounted Pumps (“M” Drive)—  
See Pages 341.3.10 - 341.3.14.*

Section	341.3
Page	341.3.6
Issue	C

SERIES SG-804, -805, -807, -810, -814 (Cast Iron)  
SGN-805, -807 (Ductile Iron)



## VIKING SG SERIES SEALLESS MAG DRIVE PUMPS

### DIMENSIONS – SERIES SG-804, SG-805 AND SGN-805 (MD-A\_“B” DRIVE) – FOOT BRACKET MOUNT

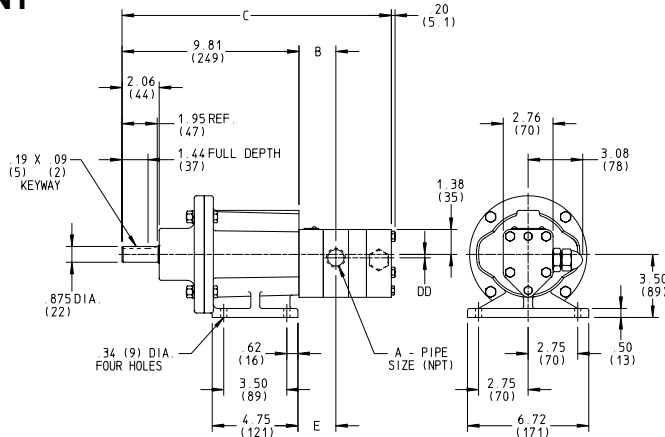

NOTE: Dimensions in inches (millimeters)

MODEL NO.	(in) A		WITH R/V			LESS R/V			DD
			B	C	E	B	C	E	
SG-80417MD-A_B	3/8	in	2.02	13.71	2.08	2.21	12.71	2.27	0.31
		mm	51	348	53	56	323	58	8
SG-80418MD-A_B	3/8	in	2.02	13.71	2.08	2.21	12.71	2.27	0.31
		mm	51	348	53	56	323	58	8
SG-80425MD-A_B	3/8	in	2.09	13.78	2.15	2.28	12.78	2.34	0.31
		mm	53	350	55	58	325	59	8
SG-80435MD-A_B	3/8	in	2.19	13.88	2.25	2.38	12.88	2.44	0.31
		mm	56	352	57	60	327	62	8
SG-80450MD-A_B	3/8	in	2.34	14.03	2.40	2.53	13.03	2.59	0.31
		mm	59	356	61	64	331	66	8
SG-80470MD-A_B	3/8	in	2.54	14.23	2.60	2.73	13.23	2.79	0.31
		mm	65	361	66	69	336	71	8
SG-80518MD-A_B SGN-80518MD-A_B	1/2	in	2.02	13.71	2.08	2.21	12.71	2.27	0.31
		mm	51	348	53	56	323	58	8
SG-80525MD-A_B SGN-80525MD-A_B	1/2	in	2.09	13.78	2.15	2.28	12.78	2.34	0.31
		mm	53	350	55	58	325	59	8
SG-80535MD-A_B SGN-80535MD-A_B	1/2	in	2.19	13.88	2.25	2.38	12.88	2.44	0.31
		mm	56	352	57	60	327	62	8
SG-80550MD-A_B SGN-80550MD-A_B	1/2	in	2.34	14.03	2.40	2.53	13.03	2.59	0.31
		mm	59	356	61	64	331	66	8
SG-80570MD-A_B SGN-80570MD-A_B	1/2	in	2.54	14.23	2.60	2.73	13.23	2.79	0.31
		mm	65	361	66	69	336	71	8
SG-80510MD-A_B SGN-80510MD-A_B	1/2	in	1.84	14.53	1.90	1.84	13.53	1.90	0.31
		mm	47	369	48	47	344	48	8
SG-80514MD-A_B SGN-80514MD-A_B	3/4	in	2.04	14.93	2.10	2.04	13.93	2.10	0.19
		mm	52	379	53	52	354	53	5
SG-80519MD-A_B SGN-80519MD-A_B	3/4	in	2.29	15.43	2.35	2.29	14.43	2.35	0.19
		mm	58	392	60	58	367	60	5
SG-80528MD-A_B SGN-80528MD-A_B	3/4	in	2.04	16.33	2.10	2.04	15.33	2.10	0.19
		mm	52	415	53	52	389	53	5



Section	341.3
Page	341.3.8
Issue	B

SERIES SG-804, -805, -807, -810, -814 (Cast Iron)  
SGN-805, -807 (Ductile Iron)



## VIKING SG SERIES SEALLESS MAG DRIVE PUMPS

### DIMENSIONS – SERIES SG-807 AND SGN-807 (MD-B\_“B” DRIVE) – FOOT BRACKET MOUNT

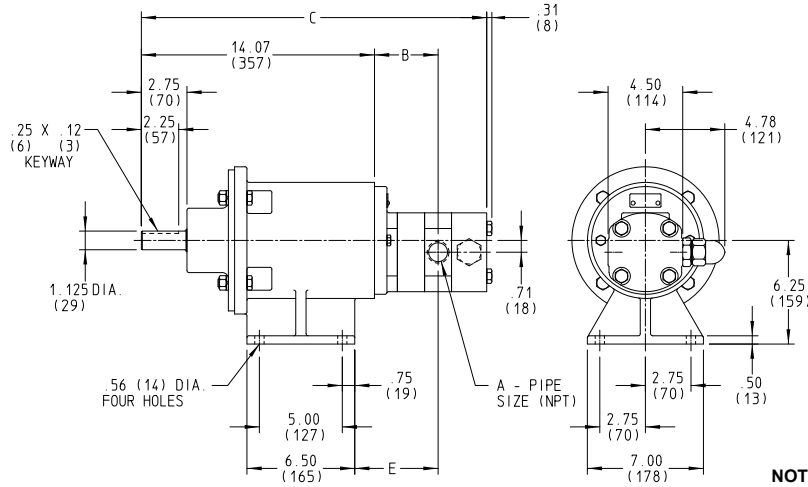

NOTE: Dimensions in inches (millimeters)

MODEL NO.	(in) A		WITH R/V			LESS R/V		
			B	C	E	B	C	E
SG-80741MD-B_B SGN-80741MD-B_B	1	in	3.07	20.07	3.13	3.26	18.45	3.32
		mm	78	510	80	83	469	84
SG-80758MD-B_B SGN-80758MD-B_B	1	in	3.24	20.24	3.30	3.43	18.61	3.49
		mm	82	514	84	87	473	89
SG-80782MD-B_B SGN-80782MD-B_B	1	in	3.48	20.48	3.54	3.67	18.86	3.73
		mm	88	520	90	93	479	95
SG-80711MD-B_B SGN-80711MD-B_B	1	in	3.81	20.81	3.87	4.00	19.19	4.06
		mm	97	529	98	102	487	103
SG-80716MD-B_B SGN-80716MD-B_B	1	in	4.31	21.30	4.37	4.50	19.68	4.56
		mm	109	541	111	114	500	116
SG-80722MD-B_B SGN-80722MD-B_B	1½ S 1¼ D	in	4.25	24.46	4.31	4.25	22.83	4.31
		mm	108	621	109	108	580	109
SG-80732MD-B_B SGN-80732MD-B_B	1½ S 1¼ D	in	4.28	24.98	4.34	4.27	23.36	4.33
		mm	109	634	110	108	593	110

S = Suction Port  
D = Discharge Port

## VIKING SG SERIES SEALLESS MAG DRIVE PUMPS

### DIMENSIONS – SERIES SG-810 (MD2-B\_“B” DRIVE) & SERIES SG-814 (MD2-C\_“B” DRIVE) FOOT BRACKET MOUNT

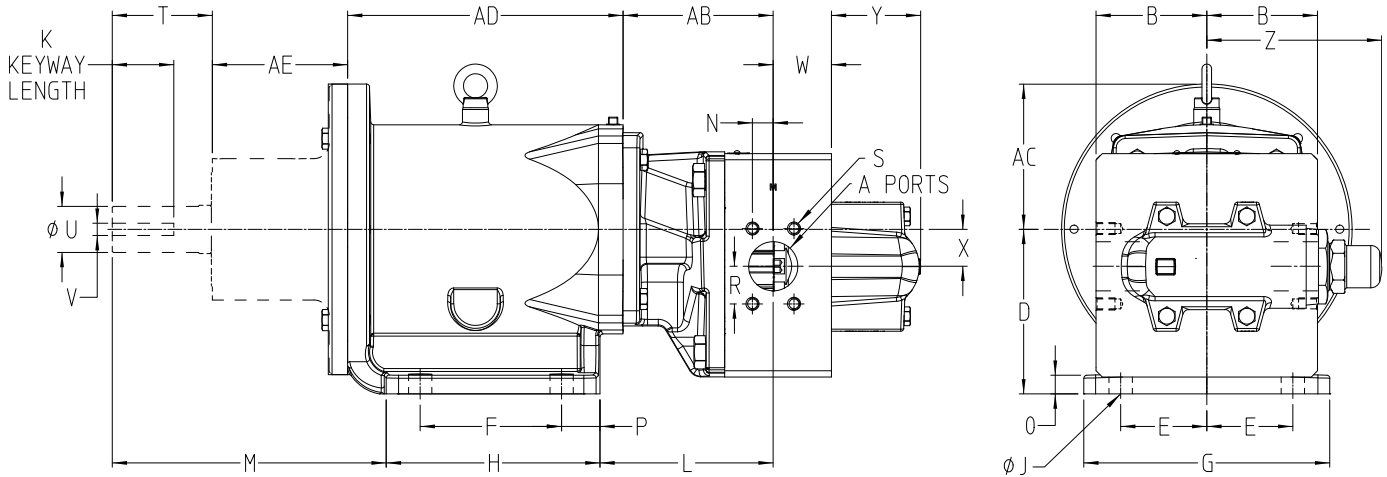

PUMP	AB	W	N	R	S	A-PORTS	X	Y	L	Z	B
SG-81009	5.35 (135.9)	2.06 (52.3)	0.51 (13.0)	1.03 (26.2)	M10	1.00"	4.50 (114.3)	3.63 (92.2)	6.42 (163.1)	6.63 (168.4)	3 (76.2)
SG-81013	5.91 (150.1)	2.13 (54.1)	1.90 (48.3)	0.70 (17.8)	M12	1.50"			6.98 (177.3)		
SG-81026	6.13 (155.7)	2.88 (73.2)	1.53 (38.9)	0.84 (21.3)	M12	2.00"			7.20 (182.9)		
SG-81420	6.10 (154.9)	2.37 (60.2)	0.84 (21.3)	1.53 (38.9)	M12	2.00"	5.19 (131.8)	3.63 (92.2)	7.04 (178.8)	7.11 (180.6)	4.5 (114.3)
SG-81436	6.80 (172.7)	3.27 (83.1)	1.21 (30.7)	2.09 (53.1)	M16	3.00"			7.74 (196.6)		
SG-81456	7.19 (182.6)	4.88 (124.0)	1.53 (38.9)	2.56 (65.0)	M16	4.00"			8.13 (206.5)		

NOTE: Dimensions in inches (millimeters)

### DIMENSIONS FOR "U" MODELS (in.)

Coupling	D	E	F	G	H	J	K	M	O	P	T	U	V	AD	AE
MD2-B (SG-810)	5.50	2.75	4.88	7.00	6.41	0.56	2.12	7.60	0.53	0.78	2.72	1.125	0.25	9.30	2.87
MD2-C (SG-814)	6.69	3.75	5.75	10.00	8.53	0.945	2.50	11.14	0.76	1.40	4.07	1.875	0.50	11.20	5.50

### DIMENSIONS FOR "M" MODELS (mm)

Coupling	D	E	F	G	H	J	K	M	O	P	T	U	V	AD	AE
MD2-B (SG-810)	145	69.9	88.9	178	127.5	14.5	46	191	13.5	19	56.0	28	8	216	77.7
MD2-C (SG-814)	170	95.0	146.0	254	216.6	24.0	63	283	19.3	35.6	103.4	48	14	284	139.7

Section	341.3
Page	341.3.10
Issue	C

SERIES SG-804, -805, -807, -810, -814 (Cast Iron)  
SGN-805, -807 (Ductile Iron)



## VIKING SG SERIES SEALLESS MAG DRIVE PUMPS

### DIMENSIONS – SERIES SG-804, SG-805 & SGN-805 (MD-A\_“M” DRIVE) – NEMA C MOTOR MOUNT – FOOTLESS BRACKET

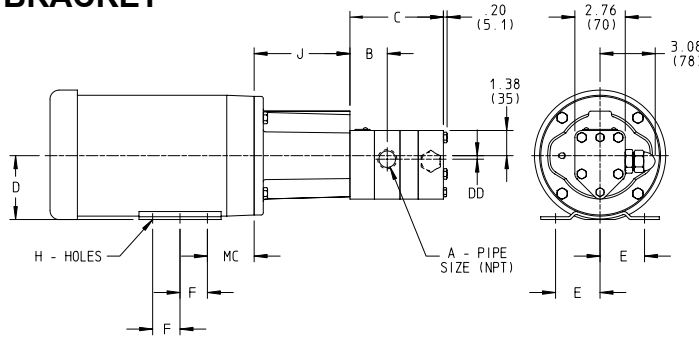

NOTE: Dimensions in inches (millimeters)

NOTE: Footless bracket requires footed motor.

MODEL NO.	(in) A	WITH R/V		LESS R/V	
		B	C	B	C
SG-80417MD-A_M	in	2.02	9.15	2.21	8.15
	mm	51	232	56	207
SG-80418MD-A_M	in	2.02	9.15	2.21	8.15
	mm	51	232	56	207
SG-80425MD-A_M	in	2.09	9.22	2.28	8.22
	mm	53	234	58	209
SG-80435MD-A_M	in	2.19	9.32	2.38	8.32
	mm	56	237	60	211
SG-80450MD-A_M	in	2.34	9.47	2.53	8.47
	mm	59	241	60	215
SG-80470MD-A_M	in	2.54	9.67	2.73	8.67
	mm	65	246	69	220
SG-80518MD-A_M SGN-80518MD-A_M	in	2.02	9.15	2.21	8.15
	mm	51	232	56	207
SG-80525MD-A_M SGN-80525MD-A_M	in	2.09	9.22	2.28	8.22
	mm	53	234	58	209
SG-80535MD-A_M SGN-80535MD-A_M	in	2.19	9.32	2.38	8.32
	mm	56	237	60	211
SG-80550MD-A_M SGN-80550MD-A_M	in	2.34	9.47	2.53	8.47
	mm	59	241	64	215
SG-80570MD-A_M SGN-80570MD-A_M	in	2.54	9.67	2.73	8.67
	mm	65	246	69	220
SG-80510MD-A_M SGN-80510MD-A_M	in	1.84	9.97	1.84	8.97
	mm	47	253	47	228
SG-80514MD-A_M SGN-80514MD-A_M	in	2.04	10.37	2.04	9.37
	mm	52	263	52	238
SG-80519MD-A_M SGN-80519MD-A_M	in	2.29	10.87	2.29	9.87
	mm	58	276	58	251
SG-80528MD-A_M SGN-80528MD-A_M	in	2.04	11.77	2.04	10.77
	mm	52	299	52	274

MOTOR FRAME SIZE	DD	D	E	F	H	(in) J	MC
56C	0.31	3.50	2.44	1.50	0.34 SLOT	5.25	2.56
	8						
	0.31	89	62	38	9		65
	8						
143TC	8	3.50	2.75	2.00	0.34	5.25	2.88
	0.31						
	8	89	70	51	9		73
	0.31						
145TC	0.31	3.50	2.75	2.50	0.34	5.25	2.88
	8						
	0.31	89	70	64	9		73
	8						
182TC	8	4.50	3.75	2.25	0.41	5.69	3.62
	0.31						
	8	114	95	57	10		92
	0.31						
184TC	0.31	4.50	3.75	2.75	0.41	5.69	3.62
	8						
	0.31	114	95	70	10		92
	8						
213TC*	5	5.25	4.25	2.75	0.41	5.69	4.5
	0.19						
	5	133	108	70	10		114
	0.19						
5							

\* Motor shaft must be modified to resemble 182TC-184TC shaft length, diameter and key.

## VIKING SG SERIES SEALLESS MAG DRIVE PUMPS

### DIMENSIONS – SERIES SG-807 AND SGN-807 (MD-A “M” DRIVE) – NEMA C MOTOR MOUNT – FOOTLESS BRACKET

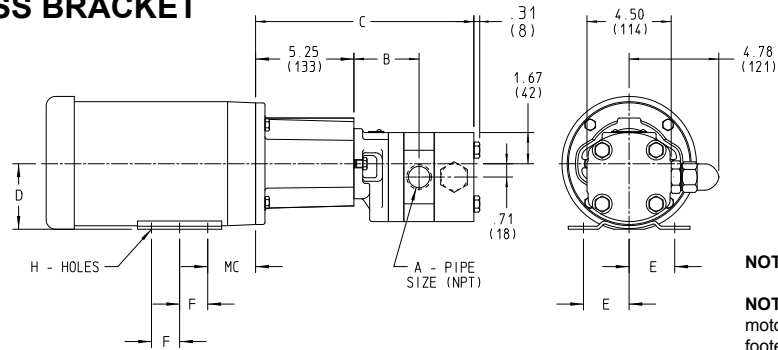

NOTE: Dimensions in inches (millimeters)

NOTE: Footless bracket requires footed motor. See page 341.3.11 for optional footed MD-A brackets.

MODEL NO.	(in) A		WITH R/V		LESS R/V	
			B	C	B	C
SG-80741MD-A_M SGN-80741MD-A_M	1	in	3.07	11.25	3.26	9.63
		mm	78	286	83	245
SG-80758MD-A_M SGN-80758MD-A_M	1	in	3.24	11.42	3.43	9.80
		mm	82	290	87	249
SG-80782MD-A_M SGN-80782MD-A_M	1	in	3.48	11.66	3.67	10.04
		mm	88	296	93	255
SG-80711MD-A_M SGN-80711MD-A_M	1	in	3.81	11.99	4.00	10.37
		mm	97	305	102	263
SG-80716MD-A_M SGN-80716MD-A_M	1	in	4.31	12.49	4.50	10.87
		mm	109	317	114	276
SG-80722MD-A_M SGN-80722MD-A_M	1½S 1¼D	in	4.25	15.64	4.25	15.02
		mm	108	397	108	356
SG-80732MD-A_M SGN-80732MD-A_M	1½S 1¼D	in	4.75	16.64	4.75	15.02
		mm	121	423	121	382

MOTOR FRAME SIZE	D	E	F	H	(in) J	MC
56C	3.50	2.44	1.50	0.34 SLOT	5.25	2.56
	89	62	38	9		65
143TC	3.50	2.75	2.00	0.34	5.25	2.88
	89	70	51	9		73
145TC	3.50	2.75	2.50	0.34	5.25	2.88
	89	70	64	9		73
182TC	4.50	3.75	2.25	0.41	5.69	3.62
	114	95	57	10		92
184TC	4.50	3.75	2.75	0.41	5.69	3.62
	114	85	70	10		92
213TC*	5.25	4.25	2.75	0.41	5.69	4.50
	133	108	70	10		114

\* Motor shaft must be modified to resemble 182TC-184TC shaft length, diameter and key.

Section	341.3
Page	341.3.12
Issue	C

SERIES SG-804, -805, -807, -810, -814 (Cast Iron)  
SGN-805, -807 (Ductile Iron)



## VIKING SG SERIES SEALLESS MAG DRIVE PUMPS

### DIMENSIONS – SERIES SG-807 AND SGN-807 (MD-A\_“M” DRIVE) – NEMA C MOTOR MOUNT – FOOTED BRACKET

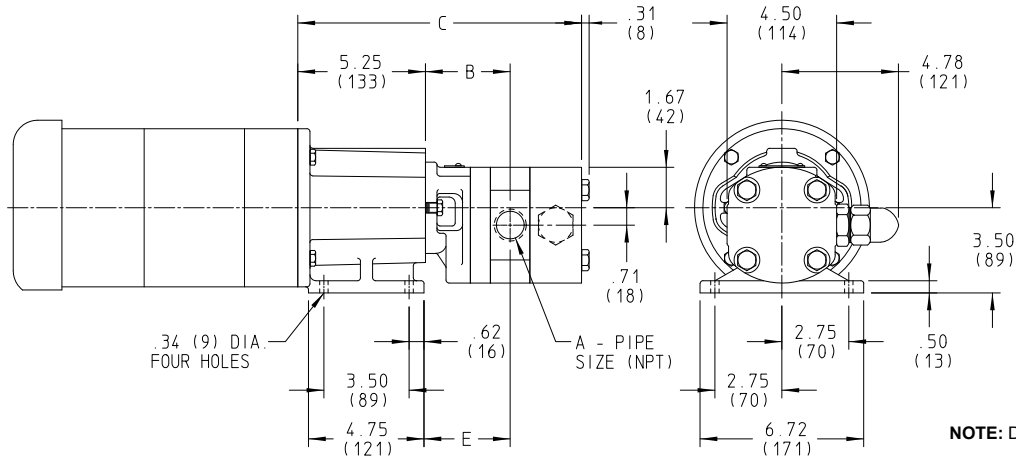

NOTE: Dimensions in inches (millimeters)

NOTE: Footed bracket requires footless motor. See pages 341.3.9 - 341.3.10 for optional footless MD-A brackets.

MODEL NO.	(in) A		WITH R/V			LESS R/V			MOTOR FRAME SIZE
			B	C	E	B	C	E	
SG-80741MD-A_M SGN-80741MD-A_M	1	in	3.07	11.25	3.13	3.26	9.63	3.32	56C 143TC 145TC
		mm	78	286	80	83	245	84	
SG-80758MD-A_M SGN-80758MD-A_M	1	in	3.24	11.42	3.30	3.43	9.80	3.49	
		mm	82	290	84	87	249	89	
SG-80782MD-A_M SGN-80782MD-A_M	1	in	3.48	11.66	3.54	3.67	10.04	3.73	
		mm	88	269	90	93	255	95	
SG-80711MD-A_M SGN-80711MD-A_M	1	in	3.81	11.99	3.87	4.00	10.37	4.06	
		mm	97	305	98	102	263	103	
SG-80716MD-A_M SGN-80716MD-A_M	1	in	4.31	12.49	4.37	4.50	10.87	4.56	
		mm	109	317	111	114	276	116	
SG-80722MD-A_M SGN-80722MD-A_M	1½S	in	4.25	15.64	4.31	4.25	14.02	4.31	
	1¼D	mm	108	397	109	108	356	109	
SG-80732MD-A_M SGN-80732MD-A_M	1½S	in	4.75	16.64	4.81	4.75	15.02	4.81	
	1¼D	mm	121	423	122	121	382	122	

S = Suction Port  
D = Discharge Port

Footed bracket is only available for up to NEMA 145TC frame motors (4.5" rabbet) - 180TC and 210TC motor frames with 8.5" rabbet are only available with footless bracket.

## VIKING SG SERIES SEALLESS MAG DRIVE PUMPS

### DIMENSIONS – SERIES SG-807 AND SGN-807 (MD-B\_“M” DRIVE) – NEMA C MOTOR MOUNT – FOOTED BRACKET

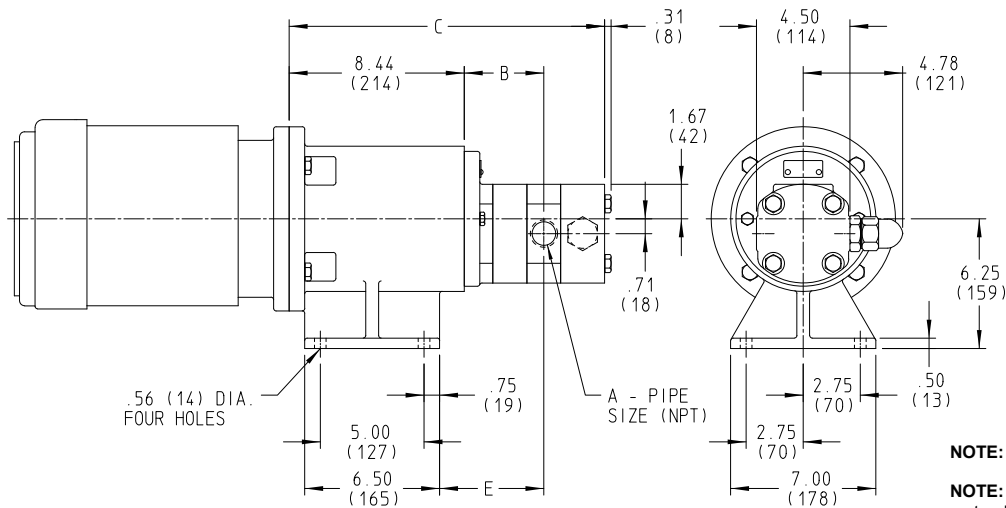

NOTE: Dimensions in inches (millimeters)

NOTE: Footed bracket requires footless motor. No footless brackets available with MD-B couplings.

MODEL NO.	(in) A		WITH R/V			LESS R/V			MOTOR FRAME SIZE
			B	C	E	B	C	E	
SG-80741MD-B_M SGN-80741MD-B_M	1	in	2.60	13.97	3.79	2.80	12.35	3.98	182TC/184TC 213TC/215TC 254TC/256TC
		mm	66	355	96	71	314	101	
SG-80758MD-B_M SGN-80758MD-B_M	1	in	2.77	14.14	3.96	2.97	12.52	4.15	
		mm	70	359	101	75	318	105	
SG-80782MD-B_M SGN-80782MD-B_M	1	in	3.01	14.38	4.20	3.21	12.76	4.39	
		mm	76	365	107	82	324	112	
SG-80711MD-B_M SGN-80711MD-B_M	1	in	3.34	14.17	4.53	3.54	13.09	4.72	
		mm	85	374	115	90	332	120	
SG-80716MD-B_M SGN-80716MD-B_M	1	in	3.84	15.20	5.03	4.04	13.59	5.22	
		mm	98	386	128	103	345	133	
SG-80722MD-B_M SGN-80722MD-B_M	1½S 1¼D	in	3.78	18.35	4.97	3.78	16.73	4.97	
		mm	96	466	126	96	425	126	
SG-80732MD-B_M SGN-80732MD-B_M	1½S 1¼D	in	4.28	19.35	5.47	4.28	17.73	5.47	
		mm	109	491	139	109	450	139	

S = Suction Port  
D = Discharge Port

Coupling will accept NEMA motor frames 182TC-256TC.  
NEMA 254TC-256TC will require shaft modification reducing shaft extension by 5/8".

Section	341.3
Page	341.3.14
Issue	C

SERIES SG-804, -805, -807, -810, -814 (Cast Iron)  
SGN-805, -807 (Ductile Iron)



## VIKING SG SERIES SEALLESS MAG DRIVE PUMPS

### DIMENSIONS – SERIES SG-810 (MD2-B\_“M” DRIVE) & SERIES SG-814 (MD2-C\_“M” DRIVE) – NEMA C AND IEC MOTOR MOUNT – FOOTED BRACKET

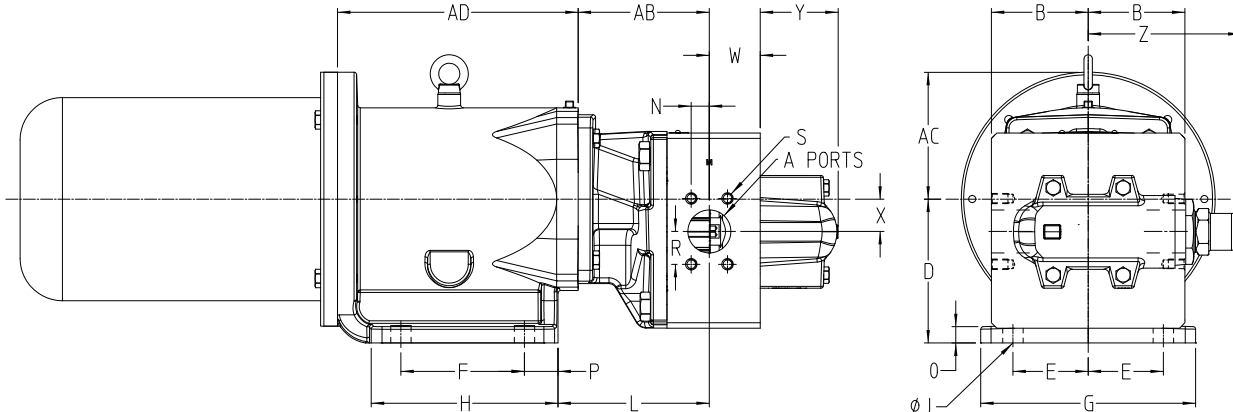

PUMP	AB	W	N	R	S	A-PORTS	X	Y	L	Z	B
SG-81009	5.35 (135.9)	2.06 (52.3)	0.51 (13.0)	1.03 (26.2)	M10	1.00"	4.50 (114.3)	3.63 (92.2)	6.42 (163.1)	6.63 (168.4)	3 (76.2)
SG-81013	5.91 (150.1)	2.13 (54.1)	1.90 (48.3)	0.70 (17.8)	M12	1.50"			6.98 (177.3)		
SG-81026	6.13 (155.7)	2.88 (73.2)	1.53 (38.9)	0.84 (21.3)	M12	2.00"			7.20 (182.9)		
SG-81420	6.10 (154.9)	2.37 (60.2)	0.84 (21.3)	1.53 (38.9)	M12	2.00"	5.19 (131.8)	3.63 (92.2)	7.04 (178.8)	7.11 (180.6)	4.5 (114.3)
SG-81436	6.80 (172.7)	3.27 (83.1)	1.21 (30.7)	2.09 (53.1)	M16	3.00"			7.74 (196.6)		
SG-81456	7.19 (182.6)	4.88 (124.0)	1.53 (38.9)	2.56 (65.0)	M16	4.00"			8.13 (206.5)		

NOTE: Dimensions in inches (millimeters)

### DIMENSIONS FOR "U" MODELS FOR NEMA C FACE MOTORS (in.)

Coupling	NEMA Drive	D	E	F	G	H	J	O	P	AD
MD2-B (SG-810)	182/184TC	5.50	2.75	4.25	7.00	5.78	0.56	0.53	0.78	8.92
	213/215TC	5.50	2.75	4.88	7.00	6.41	0.56	0.53	0.78	9.30
	254/256TC	6.50	2.75	5.50	7.00	7.03	0.56	0.53	0.78	9.92
MD2-C (SG-814)	213 thru 256TC	6.69	3.75	5.75	10.00	8.53	0.945	0.76	1.40	11.95
	284/286TC	6.69	3.75	5.75	10.00	8.53	0.945	0.76	1.40	12.49

### DIMENSIONS FOR "M" MODELS FOR IEC B5 FLANGE MOTORS (mm)

Requires unfooted motor.

Coupling	IEC Drive	D	E	F	G	H	J	O	P	AD
MD2-B (SG-810)	100/112	145	69.9	88.9	178	127.5	14.5	13.5	19	216
	132	170	69.9	108.0	178	146.3	14.5	13.5	19	236
MD2-C (SG-814)	132	170	95.0	146.0	254	216.6	24.0	19.3	35.6	284
	160/180	203	120.0	165.0	305	235.0	24.0	19.3	35	314



SERIES SG-804, -805, -807, -810, -814 (Cast Iron)  
SGN-805, -807 (Ductile Iron)

Section	341.3
Page	341.3.15
Issue	C

## VIKING SG SERIES SEALLESS MAG DRIVE PUMPS

---

### PERFORMANCE CURVE NOTES

Printed performance curves are not available.

Performance curves can be electronically generated with the Viking Pump Selector Program. This program can be located on [www.vikingpump.com/pumpselector](http://www.vikingpump.com/pumpselector) for the general public.

For authorized distributors, this program can be found listed under the "Products" tab at [www.idexconnect.com](http://www.idexconnect.com). Security passwords are required to access IDEXconnect.